

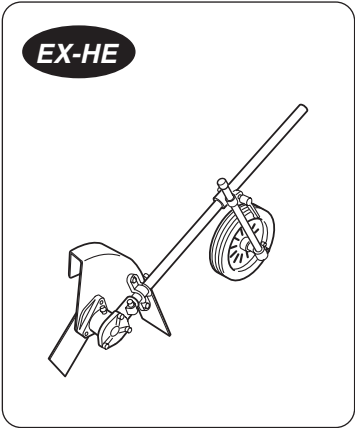

OWNER/OPERATOR MANUAL

Extre™

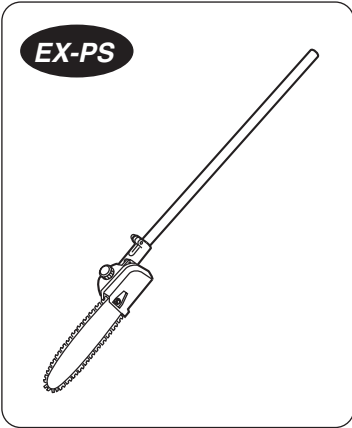
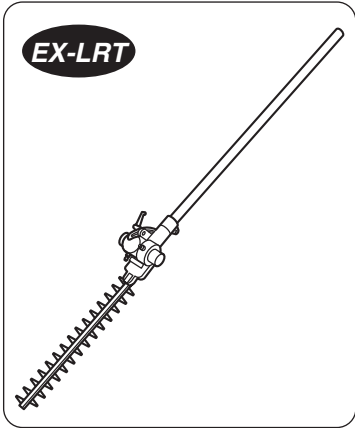
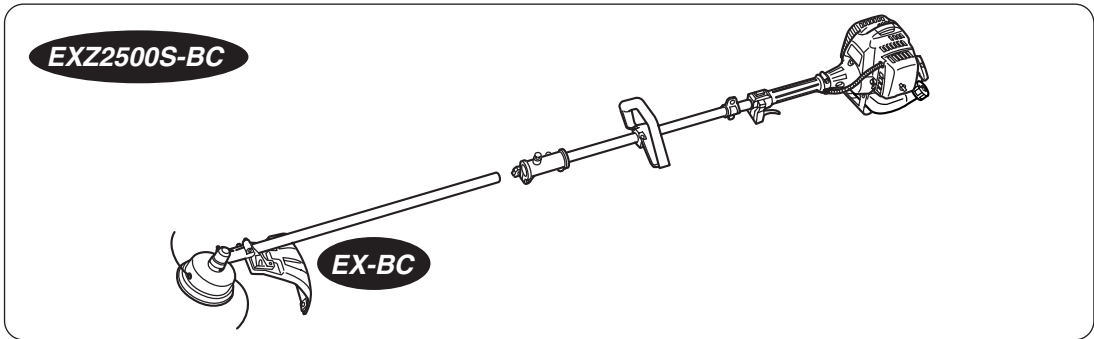

⚠ WARNING ⚠
 The engine exhaust from this product contains chemicals known to the State of California to cause cancer, birth defects or other reproductive harm.

⚠ WARNING ⚠
 Before using our products, please read this manual carefully to understand the proper use of your unit.

APPLICABLE SERIAL NUMBERS :

EXZ-PU	302845	and up	ENGINE UNIT 352001 and up
EX-BC	302960	and up	
EX-LRT	000531	and up	
EX-PS	000000	and up	
EX-HE	000101	and up	



SAFETY FIRST

Instructions contained in warnings within this manual marked with a  symbol concern critical points which must be taken into consideration to prevent possible serious bodily injury, and for this reason you are requested to read all such instructions carefully and follow them without fail.

■ WARNINGS IN THE MANUAL



This mark indicates instructions which must be followed in order to prevent accidents which could lead to serious bodily injury or death.



This mark indicates instructions which must be followed, or it leads to mechanical failure, breakdown, or damage.



This mark indicates hints or directions useful in the use of the product.

CONTENTS

1. Parts location	4
2. Specifications	5
3. Warning labels on the machine	6
4. Symbols on the machine	7
5. For safe operation	8
6. Set up	14
7. Fuel	20
8. Operation	22
9. Maintenance	35
10. Storage	45
11. Troubleshooting guide	46
12. Parts list	47

1. Parts location

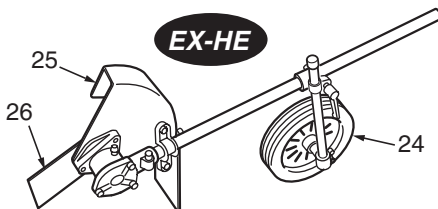
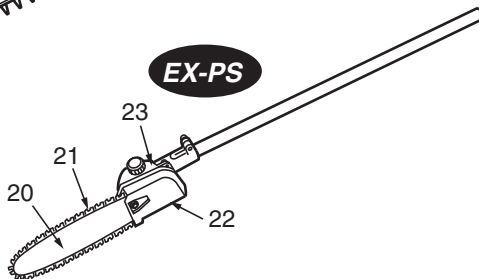
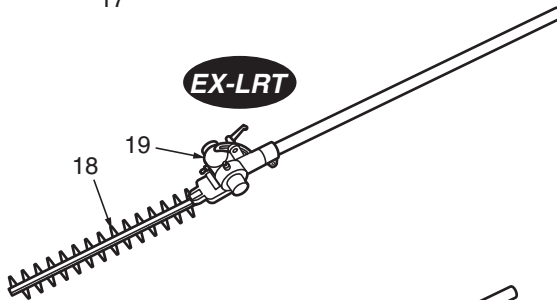
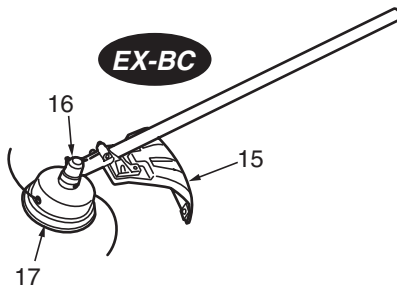
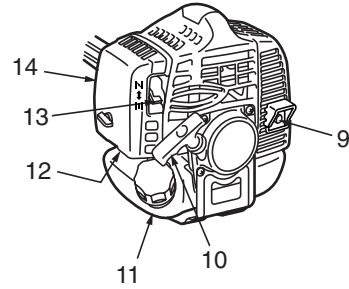
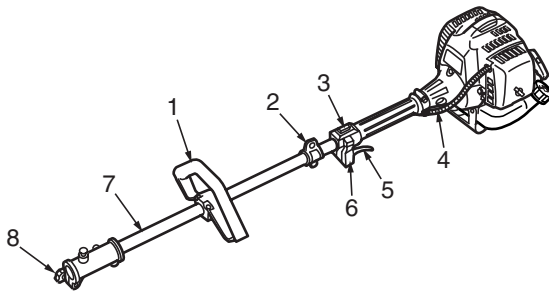

1. Loop handle
2. Shoulder strap hanger
3. Ignition switch
4. Throttle cable
5. Throttle lever
6. Throttle set button
7. Drive shaft housing
8. Knob bolt
9. Spark arrester
10. Starter knob
11. Fuel tank
12. Primer pump
13. Choke lever
14. Air cleaner cover
15. Debris guard
16. Gear case
17. Cutting line head
18. Blade
19. Gear case
20. Guide bar
21. Saw chain
22. Chain cover
23. Gear case
24. Wheel
25. Blade guard
26. Blade

3. Warning labels on the machine

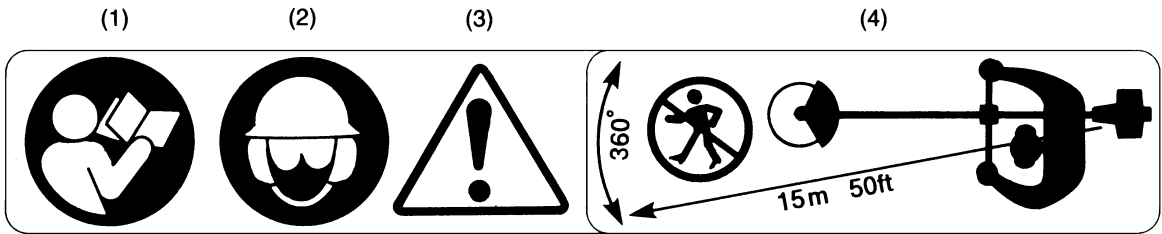

- (1) Read owner's manual before operating this machine.
- (2) Wear head, eye and ear protection.
- (3) Warning/Attention
- (4) Keep all children, bystanders and helpers 15 meters away from the machine.

! IMPORTANT

If warning label peel off or become soiled and impossible to read, you should contact the dealer from which you purchased the product to order new labels and affix them in the required location(s).

! WARNING

Never modify your machine.

We won't warrant the machine, if you use the remodeled brushcutter or you don't observe the proper usage written in the manual.

4. Symbols on the machine

For safe operation and maintenance, symbols are carved in relief on the machine. According to these indications, please be careful not to make a mistake.



(a)

(a) The port to refuel the "MIX GASOLINE"
Position: FUEL TANK CAP



(b)

(b) The direction to close the choke
Position: AIR CLEANER COVER



(c)

(c) The direction to open the choke
Position: AIR CLEANER COVER

(EX-PS Only)

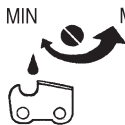

(d)

(d) If you turn the rod by screwdriver follow the arrow to the "MAX" position, the chain oil flow more, and if you turn to the "MIN" position, less.
Position: Bottom of the GEAR CASE

IMPORTANT ENGINE INFORMATION

THIS ENGINE MEETS U.S. EPA PH2
AND 2001 CALIFORNIA EMISSION
REGULATIONS FOR SI SORE's
COMPLIANCE PERIOD : CATEGORYA:

ENGINE FAMILY : 1KZXS.0254QR ; EM
ENGINE DISPLACEMENT : 25.4cc
REFER TO OWNER'S MANUAL FOR MAINTENANCE SPECIFICATIONS AND ADJUSTMENTS.



RedMax[®]
KOMATSU ZENOAH CO.

INFORMATION IMPORTANTE CONCERNANT LE MOTEUR

Ce moteur est conforme aux normes U.S.
EPA PH2 et 2001 ainsi qu'aux autres dispositions
ultérieures de la réglementation concernant la pollution
de l'air pour les petits moteurs tout-terrain avec une
période de accordable : CATEGORYA.

Type de moteur : 1KZXS.0254QR :EM
Cylindrée du moteur : 25,4cc
Se référer au Manuel de l'utilisateur pour les
spécifications d'entretien et les réglages.



RedMax[®]
KOMATSU ZENOAH CO.

5. For safe operation

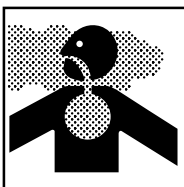
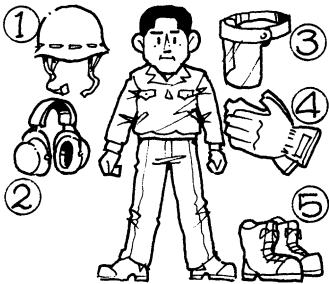

1. Read this manual carefully until you completely understand and follow all safety and operating instructions.
2. Keep this manual handy so that you may refer to it later whenever any questions arise. Also note, if you have any questions which cannot be answered herein, contact the dealer from whom you purchased the product.
3. Always be sure to include this manual when selling, lending, or otherwise transferring the ownership of this product.
4. Never allow children or anyone unable to fully understand the directions given in the manual to use the machine.

■ WORKING CONDITION

1. When using the product, you should wear proper clothing and protective equipment.

(1) Helmet

(2) Ear protectors

(3) Protection goggles or face protector

(4) Thick work gloves

(5) Non-slip-sole work boots

2. And you should carry with you.

- (1) Attached tools
- (2) Properly reserved fuel
- (3) Spare blade
- (4) Things to notify your working area (rope, warning signs)
- (5) Whistle (for collaboration or emergency)
- (6) Hatchet or saw (for removal of obstacles)

3. Do not wear loose clothing, jewelry, short trousers, sandals, or go barefoot. Do not wear anything which might be caught by a moving part of the unit. Secure hair so it is above shoulder length.

■ WORKING CIRCUMSTANCE

1. Never start the engine inside a closed room or building. Exhaust gases contain dangerous carbon monoxide.
2. Never use the product,
 - a. when the ground is slippery or when you can't maintain a steady posture.



5. For safe operation



- b. At night, at times of heavy fog, or at any other times when your field of vision might be limited and it would be difficult to gain a clear view of the working area.
- c. During rain storms, during lightning storms, at times of strong or gale-force winds, or at any other times when weather conditions might make it unsafe to use the product.



■ WORKING PLAN

1. You should never use the product when under the influence of alcohol, when suffering from exhaustion or lack of sleep, when suffering from drowsiness as a result of having taken cold medicine or at any other time when a possibility exists that your judgment might be impaired or that you might not be able to operate the product properly and in a safe manner.
2. When planning your work schedule, allow plenty of time to rest. Limit the amount of time over which the product is to be used continuously to somewhere around 30~40 minutes per session, and take 10~20 minutes of rest between work sessions. Also try to keep the total amount of work performed in a single day under 2 hours or less.



▲ WARNING

1. If you don't observe the working time, or working manner (See ■ USING THE PRODUCT), Repetitive Stress Injury (RSI) could occur.
If you feel discomfort, redness and swelling of your fingers or any other part of your body, see a doctor before getting worse.
2. To avoid noise complaints, in general, operate product between 8a.m. and 5p.m. on weekdays and 9a.m. to 5p.m. weekends.

📖 NOTE

Check and follow the local regulations as to sound level and hours of operations for the product.



5. For safe operation

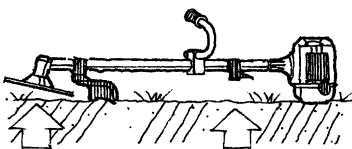
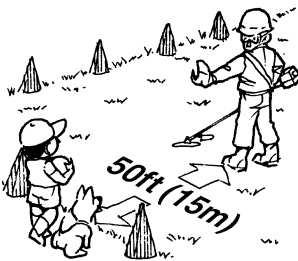
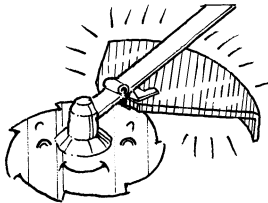
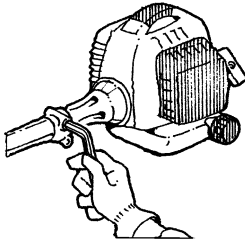
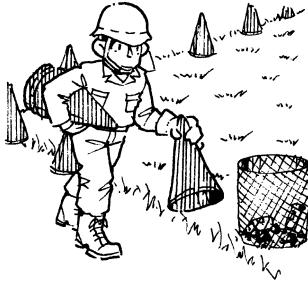

■ BEFORE STARTING THE ENGINE

1. The area within a perimeter of 50 feet (15m) of the person using the product should be considered a hazardous area into which no one should enter. If necessary yellow warning rope, warning signs should be placed around the perimeter of the area. When work is to be performed simultaneously by two or more persons, care should also be taken to constantly look around or otherwise check for the presence and locations of other people working so as to maintain a distance between each person sufficient to ensure safety.
2. Check the condition of working area to avoid any accident by hitting hidden obstacles such as stumps, stones, cans, or broken grass.

! IMPORTANT

Remove any obstacle before beginning work.

3. Inspect the entire unit for loose fasteners and fuel leakage. Make sure that the cutting attachment is properly installed and securely fastened.
4. Be sure the debris guard is firmly attached in place.
5. Always use the shoulder strap. Adjust the strap for comfort before starting the engine. The strap should be adjusted so the left hand can comfortably hold the handlebar grip approximately waist high.

■ STARTING THE ENGINE

1. Keep bystanders and animals at least 50feet (15m) away from the operating point. If you are approached, immediately stop the engine.
2. The product is equipped with a centrifugal clutch mechanism, so the cutting attachment begins to rotate as soon as the engine is started by putting the throttle into the start position. When starting the engine, place the product onto the ground in a flat clear area and hold it firmly in place so as to ensure that neither the cutting part nor the throttle come into contact with any obstacle when the engine starts.

! 5. For safe operation

! WARNING

Never place the throttle into the high speed position when starting the engine.

3. After starting the engine, check to make sure that the cutting attachment stops rotating when the throttle is moved fully back to its original position. If it continues to rotate even after the throttle has been moved fully back, turn off the engine and take the unit to your authorized Red Max servicing dealer for repair.

■ USING THE PRODUCT

! IMPORTANT

Cut only materials recommended by the manufacturer. And use only for tasks explained in the manual.

1. Grip the handles firmly with both hands using your whole hand. Place your feet slightly apart (slightly further apart than the width of your shoulders) so that your weight is distributed evenly across both legs, and always be sure to maintain a steady, even posture while working.
2. Keep cutting attachment below waist level.
3. Maintain the speed of the engine at the level required to perform cutting work, and never raise the speed of the engine above the level necessary.
4. If the unit start to shake or vibrate, turn off the engine and check the whole unit. Do not use it until the trouble has been properly corrected.
5. Keep all parts of your body away from rotating cutting attachment and hot surfaces.
6. Never touch the muffler, spark plug, or other metallic parts of the engine while the engine is in operation or immediately after shutting down the engine. Doing so could result in serious burns or electrical shock.

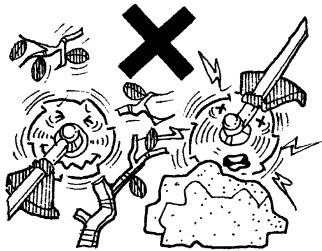



5. For safe operation

• IF SOMEONE COMES

1. Guard against hazardous situations at all times. Warn adults to keep pets and children away from the area. Be careful if you are approached. Injury may result from flying debris.
2. If someone calls out or otherwise interrupts you while working, always be sure to turn off the engine before turning around.



■ MAINTENANCE

1. In order to maintain your product in proper working order, perform the maintenance and checking operations described in the manual at regular intervals.
2. Always be sure to turn off the engine before performing any maintenance or checking procedures.

▲ WARNING

The metallic parts reach high temperatures immediately after stopping the engine.

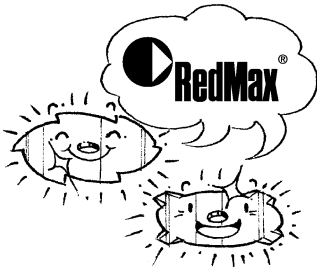

3. When replacing the cutting attachment or any other part, or when replacing the oil or any lubricant, always be sure to **use only RedMax products or products which have been certified by RedMax for use with the RedMax product.**
4. In the event that any part must be replaced or any maintenance or repair work not described in this manual must be performed, please contact a representative from the store nearest RedMax authorized servicing dealer for assistance.
5. Do not use any accessory or attachment other than those bearing the RedMax mark and recommended for the unit.
6. Under no circumstances should you ever take apart the product or alter it in any way. Doing so might result in the product becoming damaged during operation or the product becoming unable to operate properly.

■ HANDLING FUEL

1. The engine of the RedMax product is designed to run on a mixed fuel which contains highly flammable gasoline. Never store cans of fuel or



5. For safe operation

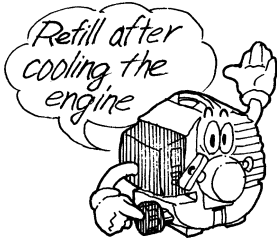

refill the tank of the unit in any place where there is a boiler, stove, wood fire, electrical sparks, welding sparks, or any other source of heat or fire which might ignite the fuel.

2. Never smoke while operating the unit or refilling its fuel tank.
3. When refilling the tank, always turn off the engine and allow it to cool down. Take a careful look around to make sure that there are no sparks or open flames anywhere nearby before refueling.
4. Wipe spilled fuel completely using a dry rag if any fuel spillage occurs during refueling.
5. After refueling, screw the fuel cap back tightly onto the fuel tank and then carry the unit to a spot 10 feet or more away from where it was refueled before turning on the engine.

■ TRANSPORTATION

1. When hand-carrying the product, cover over the cutting part if necessary, lift up the product and carry it paying attention to the blade.
2. Never transport the product over rough roads over long distances by vehicle without removing all fuel from the fuel tank. If doing so, fuel might leak from the tank during transport.

6. Set up

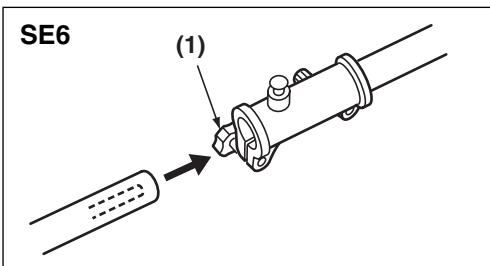
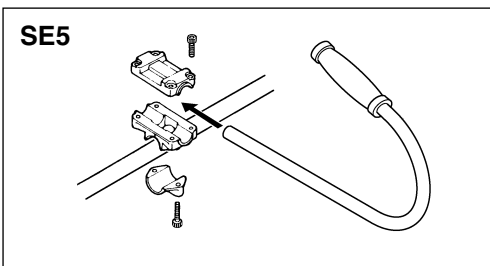
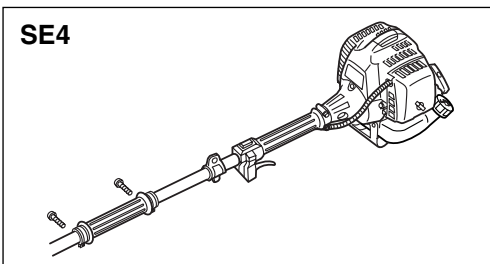
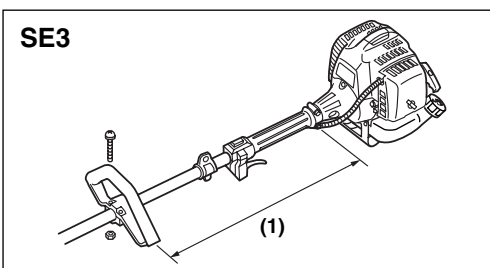
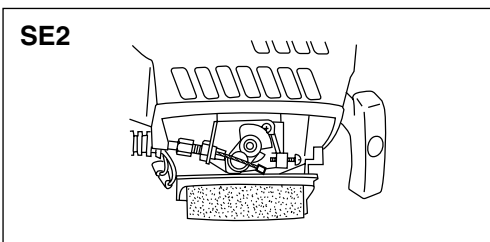
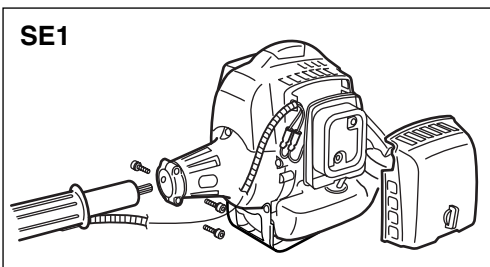

■ MOUNTING ENGINE (SE1)

1. Push the driveshaft housing toward the clutch housing and rotate it by hand to check that the driveshaft is engaged with the gears.
2. Insert the driveshaft housing into the clutch housing until it bottoms, and align the positioning holes on the clutch housing and the shaft tube and install the screw. When difficult to engage, twist the engine slightly.
3. Fasten the clamp securely with two screws.

❗ IMPORTANT

Tighten the screws gradually by turns.

■ CONNECTING THROTTLE WIRE

1. Remove the air cleaner cover.
2. Connect the end of the throttle wire to the joint on the top of the carburetor. (SE2)

■ CONNECTING SWITCH WIRES

- Connect the switch wires between the engine and the main unit. Pair the wires of the same color.

■ INSTALLING HANDLE

(EX-BC, EX-LRT only) (SE3)

- Install the handle to the shaft tube and clamp it at a location that is comfortable to you.

(1) About 19 inches (48cm)

(EX-PS only) (SE4)

- Insert the grip to the shaft tube.
- Fasten the clamps with screws.

(EX-HE only) (SE5)

- Install the J-shaped handle to the shaft tube and clamp at a position best for your job.

■ JOINT ATTACHMENT (SE6)

- Insert the attachment to the main shaft.
- Tighten the knob bolt securely.

(1) Knob bolt

6. Set up (EX-BC only)

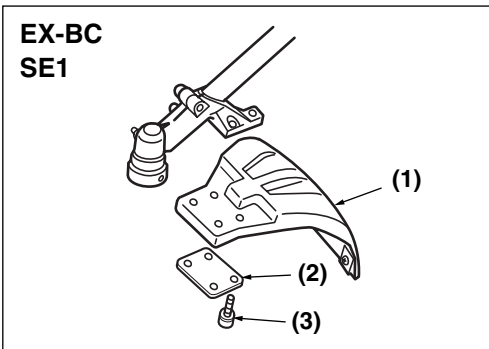

■ INSTALLING DEBRIS GUARD

- Put the debris guard on the gear box, attach it with the 4 screws and hardware provided. (SE1)

(1) debris guard

(2) plate

(3) screw

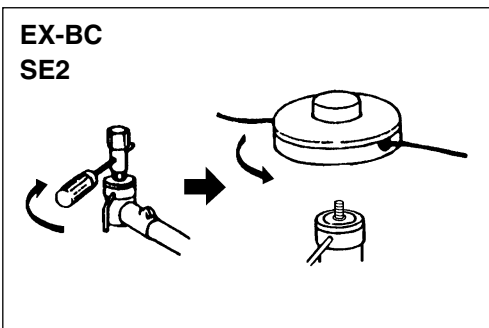

■ INSTALLING CUTTING HEAD (SE2)

1. While locking the gear shaft, by inserting the supplied tool into the upper holder on the gear box, loosen and remove the hexagon nut(left-handed)
2. Then screw in the cutting head to the gear shaft over the holders. Hand-tighten it securely.



■ BALANCE UNIT

1. Put on strap and attach unit to strap.
2. Slide clamp up or down until unit balances with head just touching on the ground. (SE3)

6. Set up (EX-LRT only)

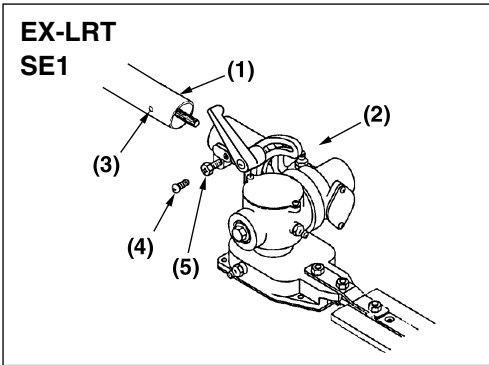

■ ATTACHING THE TRIMMING MECHANISM (SE1)

1. Remove the screw screwed into the end of the trimming mechanism.
2. Insert the end of the trimming mechanism into the main pipe.
3. Line up the hole on the end of the trimming mechanism into which the screw is to be inserted with the hole on the main pipe, and screw the screw firmly in.
4. Using a wrench, screw in the bolt provided to fix the trimming mechanism into place.

(1) Main pipe

(2) Trimming mechanism

(3) Screw hole

(4) Screw

(5) Fastening bolt

■ BALANCE UNIT

1. Put on strap and attach unit to strap.
2. Depending on the working posture, slide clamp up or down until unit balances and the strap fits your body.

6. Set up (EX-PS only)

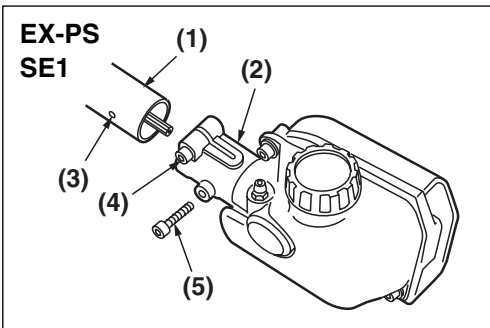

■ ATTACHING THE PRUNING MECHANISM (SE1)

1. Remove the cap on the end of the main pipe.
2. Remove the screw screwed into the end of the gear case.
3. Insert the end of the gear case into the main pipe.
4. Line up the hole on the end of the gear case into which the screw is to be inserted with the hole on the main pipe, and screw the screw firmly in.
5. Using a wrench, screw in the bolt provided to fix the mechanism into place.

- (1) Main pipe
- (2) Gear case
- (3) Screw hole
- (4) Fastening bolt
- (5) Bolt

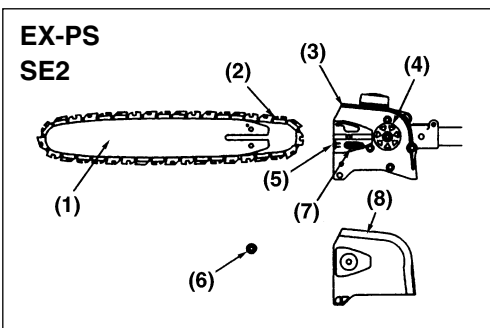

A standard package contains the items as shown below. (SE2)

- (1) Guide bar
- (2) Saw chain
- (3) Gase case
- (4) Sprocket
- (5) Chain tension adjust screw
- (6) Nut
- (7) Chain tensioner nut
- (8) Chain cover

Install the guide bar and the saw chain on the gear case as follows.

⚠ WARNING

The saw chain has very sharp edges. Use protective gloves for safety.

1. Loosen a nut and remove the chain cover.
2. Mount the guide bar then fit the saw chain around the bar and sprocket. (SE3)

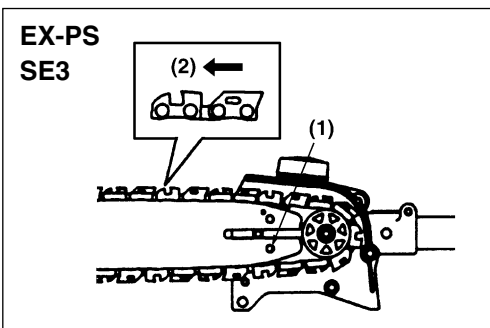

⚠ WARNING

Pay attention to the correct direction of the saw chain

6. Set up (EX-PS only)

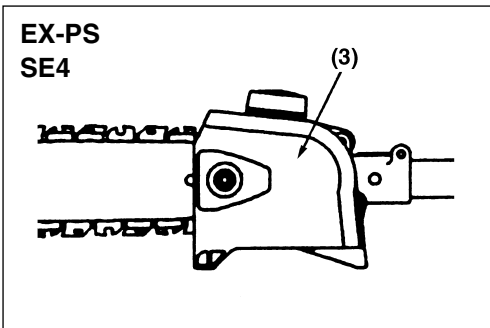

3. Fit the chain tensioner nut into the lower hole of the guide bar, then install the chain cover, and fasten the mounting nut to finger tightness. (SE3)(SE4)

- (1) Hole
(2) Moving direction
(3) Chain tensioner nut

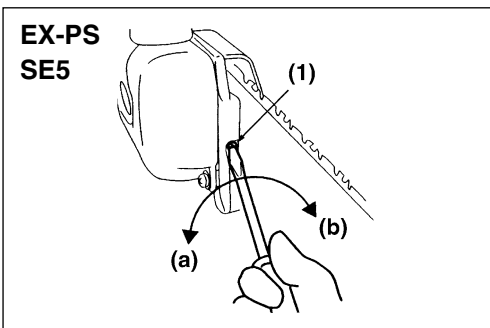

4. Adjust the chain tension by turning the tensioner screw until the tie straps just touch the bottom side of the bar rail. (SE5)

- (1) Chain tension adjusting screw
(a) Loosen
(b) Tighten

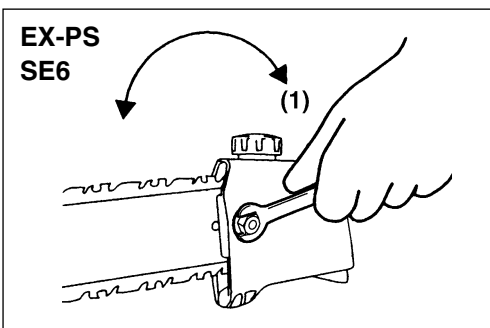

5. Tighten the mounting nut securely with the bar tip held up (SE6)(TORQUE: 8.9~11.7 N.m./90~120 kg-cm). Then check the chain for smooth rotation and correct tension while moving it by hand. If necessary, readjustment.

- (1) Tighten

⚠ WARNING

It is very important to maintain the proper chain tension. Rapid wear of the guide bar or the chain coming off easily can be caused by improper tension. Especially when using a new chain, take good care of it since it should expand when first used.

■ BALANCE UNIT

1. Put on strap and attach unit to strap.
2. Depending on the working posture, slide clamp up or down until unit balances and the strap fits your body.

6. Set up (EX-HE only)

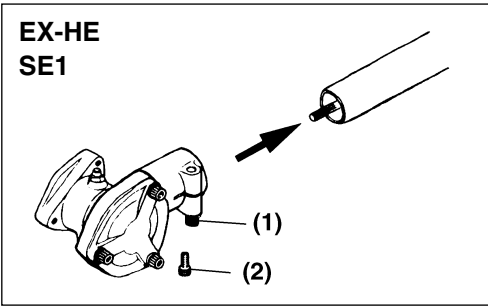

1. Insert the driveshaft into the clutch drum, then attach the gearbox to the shaft tube as aligning the positioning holes. Wipe out grease on the tube and the inside of the gearbox. Screw in the lock screw and fasten the clamp bolt firmly. (SE1)

- (1) Clamp bolt
- (2) Lock screw

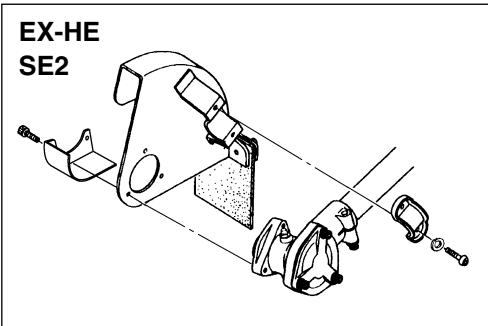

2. Install the blade guard to the gear case with the provided 3 screws, then clamp it to the shaft tube with 2 screws. (SE2)

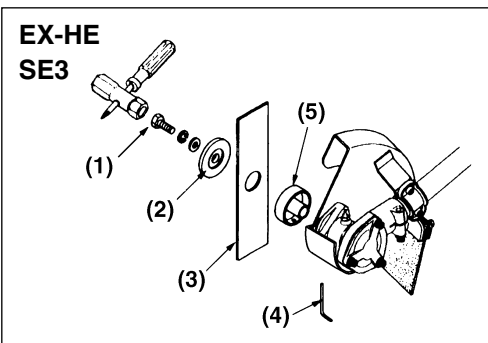

3. Place the blade between the cutter holders (A) and (B) while locking the gear shaft by putting the bar, one of the tools provided, through the key holes on the holder(A) and the gearcase. Use the socket and the screwdriver as shown in the picture below to tighten the blade mounting bolt. (SE3)

- (1) Blade mounting bolt (Left-handed)
- (2) Cutter holder (B)
- (3) Blade
- (4) Bar
- (5) Cutter holder (A)

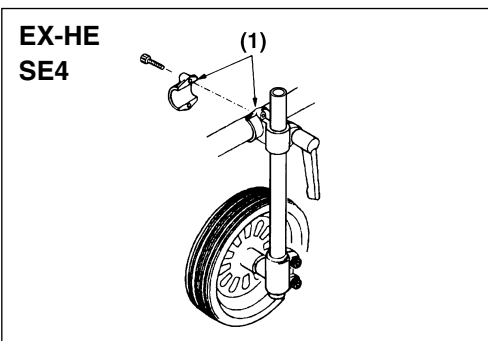

4. Split the bracket and install the wheel assembly to the shaft tube and clamp at a position best for your job. (SE4)

- (1) Bracket

7. Fuel

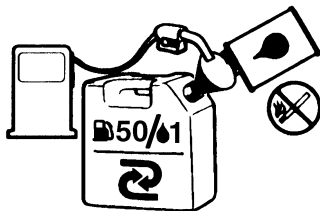

50:1 MIXING CHART

GASOLINE	gal.	1	2	3	4	5
2-CYCLE OIL	fl.oz	2.6	5.2	7.8	10.4	13

GASOLINE	liter	1	2	3	4	5
2-CYCLE OIL	ml	20	40	60	80	100

⚠ WARNING

- Gasoline is very flammable. Avoid smoking or bringing any flame or sparks near fuel. Make sure to stop the engine and allow it cool before refueling the unit. Select outdoor bare ground for fueling and move at least 3m(10ft) away from the fueling point before starting the engine.
- The RedMax engines are lubricated by oil specially formulated for air-cooled 2-cycle gasoline engine use. If RedMax oil is not available, use an anti-oxidant added quality oil expressly labeled for air-cooled 2-cycle engine use. (JASO FC GRADE OIL or ISO EGC GRADE)

RECOMMENDED MIXING RATIO GASOLINE 50:OIL 1

- Exhaust emission are controlled by the fundamental engine parameters and components(eq., carburation, ignition timing and port timing) without addition of any major hardware or the introduction of an inert material during combustion.
- These engines are certified to operate on unleaded gasoline.
- Make sure to use gasoline with a minimum octane number of 90 ROZ(USA/Canada : pump octane min.87)
- Unleaded gasoline is recommended to reduce the contamination of the air for the sake of your health and the environment.
- Poor quality gasolines or oils may damage sealing rings, fuel lines or fuel tank of the engine.

■ HOW TO MIX FUEL

1. Measure out the quantities of gasoline and oil to be mixed.
2. Put some of the gasoline into a clean, approved fuel container.
3. Pour in all of the oil and agitate well.
4. Pour in the rest of gasoline and agitate again for at least one minute.
5. Put a clear indication on the outside of the

7. Fuel

container to avoid mixing up with gasoline or other containers.

6. Indicate the contents on outside of container for easy identification.

■ FUELING THE UNIT

1. Untwist and remove the fuel cap. Rest the cap on a dustless place.
2. Put fuel into the fuel tank to 80% of the full capacity.
3. Fasten the fuel cap securely and wipe up any fuel spillage around the unit.

WARNING

1. Select bare ground for fueling.
2. Move at least 10 feet (3 meters) away from the fueling point before starting the engine.
3. Stop the engine before refueling the unit.

FOR YOUR ENGINE LIFE, AVOID;

1. **FUEL WITH NO OIL(RAW GASOLINE)** – It will cause severe damage to the internal engine parts very quickly.
2. **GASOHOL** – It can cause deterioration of rubber and/or plastic parts and disruption of engine lubrication.
3. **OIL FOR 4-CYCLE ENGINE USE or WATER COOLED 2-CYCLE ENGINE USE** – It can cause spark plug fouling, exhaust port blocking, or piston ring sticking.
4. **Mixed fuels which have been left unused for a period of one month or more** may clog the carburetor and result in the engine failing to operate properly.

8. Operation

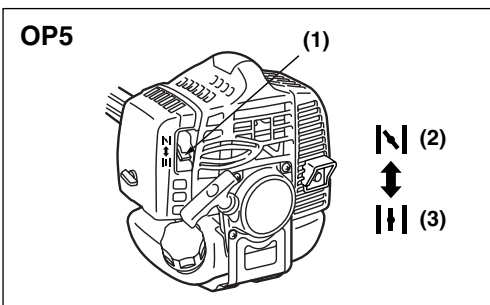
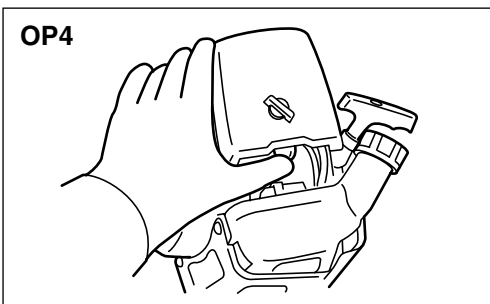
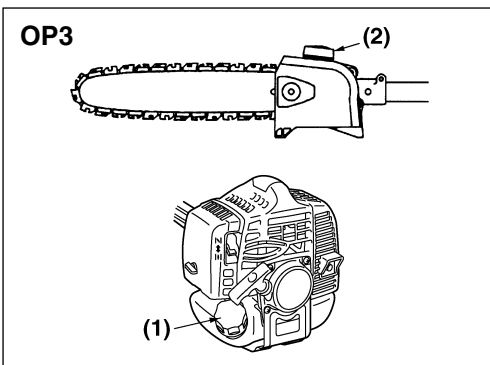
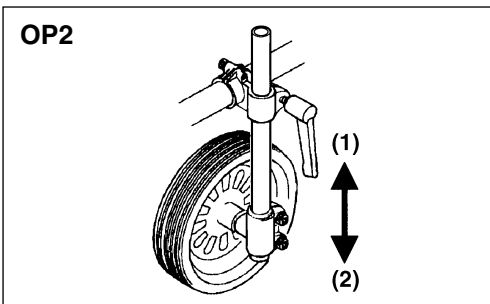
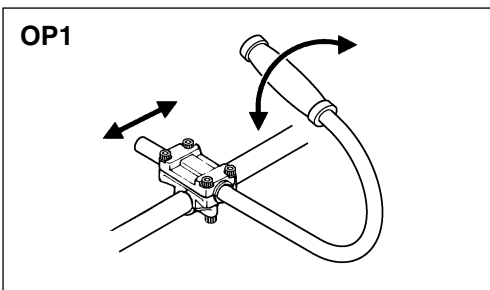

(EX-HE only)

■ STARTING ENGINE

The RedMax stick edge is designed for edging lawn in gardens, parks, roadsides and so on.

Before starting the engine, take the operating position and adjust the handle position and the wheel height as necessary.

ADJUSTING HANDLE POSITION

- Loosen the handle bracket screws and reposition the handle to your best operating position. Re-tighten the screws. (OP1)

ADJUSTING WHEEL HEIGHT

- Loosen the clamp lever and change the wheel height to obtain desired cutting depth. (OP2)

(1) Deep cut

(2) Shallow cut



- Never adjust wheel height with the engine running.



The cutting head will start rotating upon the engine starts.

1. Feed fuel into the fuel tank and tighten the cap securely. (OP3)(1)

(EX-PS only) Feed the chain oil into the oil tank and tighten the cap securely, too. (OP3)(2)

(1) Fuel

(2) Chain oil

2. Rest the unit on a flat, firm place. Keep the cutting head off the ground and clear of surrounding objects as it will start rotating upon starting of the engine.

3. Push the primer pump several times until overflow fuel flows out in the clear tube. (OP4)

4. Move the choke lever to the closed position. (OP5)

5. Set the ignition switch to the “start” position. While pulling the throttle lever, push the set button, and release the throttle, then the throttle

8. Operation

- lever is in to the “start” position. (OP6)
6. While holding the unit firmly, pull out the starter rope quickly until engine fires. (OP7)

- (1) choke lever (2) close (3) open
(4) ignition switch (5) start (6) stop
(7) throttle set button

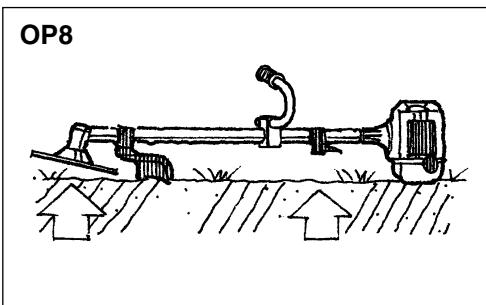
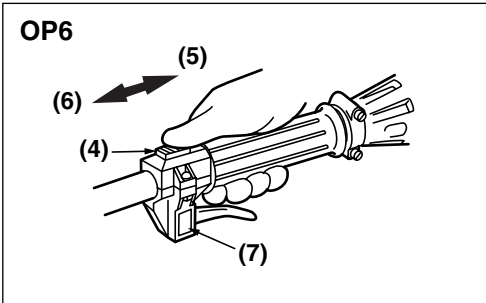

⚠ WARNING

The product is equipped with a centrifugal clutch mechanism, so the cutting attachment begins to rotate as soon as the engine is started by putting the throttle into the start position. When starting the engine, place the product onto the ground in a flat clear area and hold it firmly in place so as to ensure that neither the cutting part nor the throttle come into contact with any obstacle when the engine starts. (OP8)

❗ IMPORTANT

- Avoid pulling the rope to its end or returning it by releasing the knob. Such actions can cause starter failures.
7. Move the choke lever downward to open the choke. And restart engine. (OP5)
8. Allow the engine to warm up for a several minutes before starting operation.

📖 NOTE

1. When restarting the engine immediately after stopping it, leave the choke open.
2. Overchoking can make the engine hard to start due to excess fuel. When the engine failed to start after several attempts, open the choke and repeat pulling the rope, or remove the spark plug and dry it.

■ STOPPING ENGINE (OP6)

1. Release the throttle lever and run the engine for a half minute.
2. Shift the ignition switch to the STOP position.

8. Operation

⚠ IMPORTANT

- Except for an emergency, avoid stopping the engine while pulling the throttle lever.

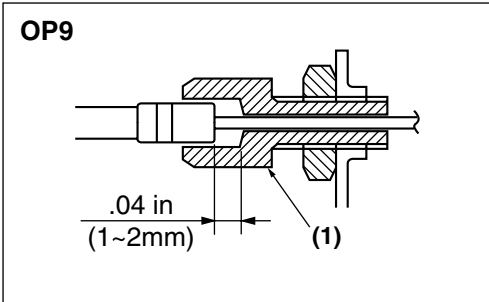

■ ADJUSTING THROTTLE CABLE

- The normal play is 1 or 2mm when measured at the carburetor side end. Readjust with the cable adjuster as required. (OP9)

(1) cable adjuster

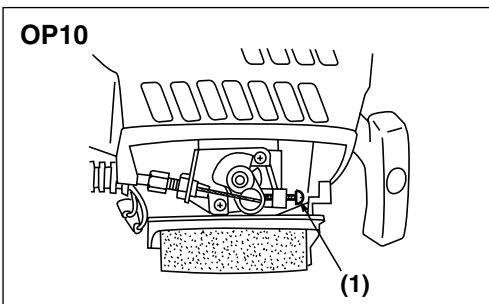

■ ADJUSTING IDLING SPEED (OP10)

1. When the engine tends to stop frequently at idling mode, turn the adjusting screw clockwise.
2. When the cutting head keeps rotating after releasing the trigger, turn the adjusting screw counter-clockwise.

(1) idle adjusting screw

📖 NOTE

- Warm up the engine before adjusting the idling speed.

8. Operation (EX-BC only)

■ CUTTING WORK (LINE HEAD USAGE)

⚠ WARNING

1. Always wear eye protection such as safety goggles. Never lean over the rotating cutting head. Rocks or other debris could be thrown into eyes and face and cause serious personal injury.
2. Keep the debris guard in place at all times when the unit is operated.

TRIMMING GRASS AND WEEDS

- Always remember that the TIP of the line does cutting. You will achieve better results by not crowding the line into the cutting area. Allow the unit to trim at its own pace.

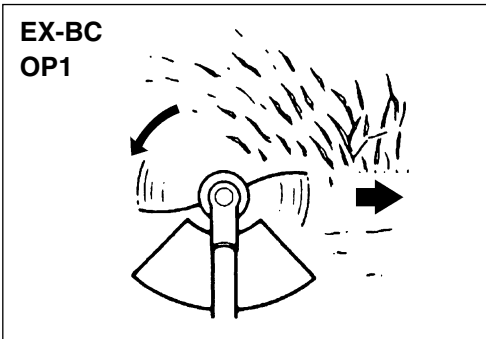













1. Hold the unit so the head is off the ground and is tilted about 20 degrees toward the sweep direction. (OP1)
2. You can avoid thrown debris by sweeping from your left to the right.
3. Use a slow, deliberate action to cut heavy growth. The rate of cutting motion will depend on the material being cut. Heavy growth will require slower action than will light growth.
4. Never swing the unit so hard as you are in danger of losing your balance or control of the unit.
5. Try to control the cutting motion with the hip rather than placing the full workload on the arm and hands.
6. Take precautions to avoid wire, grass and dead, dry, long-stem weeds from wrapping around the head shaft. Such materials can stall the head and cause the clutch to slip, resulting in damage to the clutch system if repeated frequently.

ADJUSTING THE LINE LENGTH

- Your brushcutters is equipped with a semi- auto type nylon line head that allows the operator to advance the line without stopping the engine. When the line becomes short, lightly tap the head on the ground while running the engine at full throttle.
- Each time the head is bumped, the line advance about 1 inch(25.4 mm). For better effect, tap the head on bear ground or hard soil. Avoid bumping in thick, tall grass as the engine may stall by overload.

8. Operation (Optional blade usage EX-BC only)

CUTTER APPLICATION CHART	9" 22-tooth: SST229	8" 8-tooth: SGB088	8" 4-tooth: SGB048	Nylon line head
	9" 24-tooth: SST249	9" 8-tooth: SGB089	9" 4-tooth: SGB049	
Under growth 				
Heavy weeds 				
Light weeds 				
Grass 				

■ CHOOSE THE BLADE

Choose a suitable recommended cutting attachment according to the object to be cut.

- When replacing blade always be sure to use products which have been certified by RedMax.

⚠ WARNING

- When sharpening, removing, or reattaching the blade, be sure to wear thick, sturdy gloves and use only proper tools and equipment to prevent injury.

■ SET UP

1. Detach the line head assembly completely. (OP2)
2. Put on the blade, making the marked side face the holder, put on the outer holders, and fasten the blade with the blade nut. (OP2)

(1) Cover: 3540-13283

(2) Holder: 6019-13250 (Attachment)

ⓘ IMPORTANT

Change to the debris guard which is suitable for the metal blade. (OP3)

TIGHTENING TORQUE: 130~174 in-lbs
(14.7~19.6 N.m.)

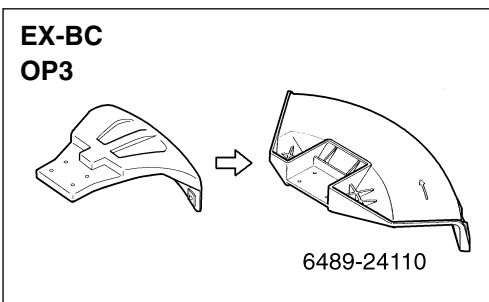
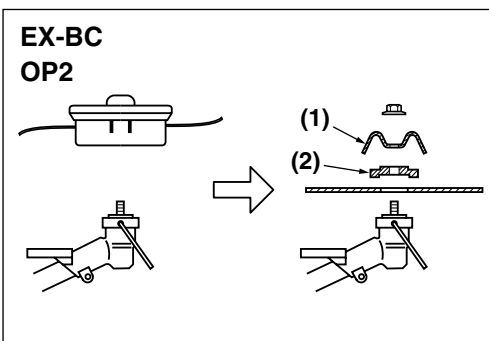

8. Operation (Optional blade usage EX-BC only)

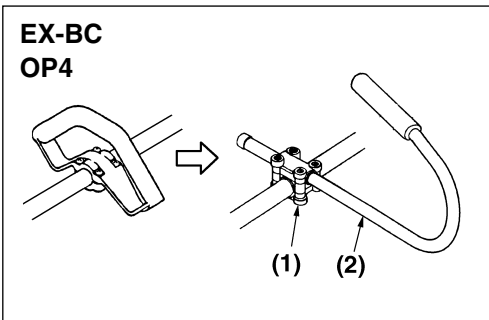

⚠ IMPORTANT

Change the loop handle to the J-handle for safe operation. (OP4)

(1) Bracket: 3583-14101

(2) J-handle: 6367-14200

■ STARTING THE ENGINE

Please refer 5. For safe operation (P.10~12), 8. Operation (P.22~23).

⚠ WARNING

- The product is equipped with a centrifugal clutch mechanism, so the cutting attachment begins to rotate as soon as the engine is started by putting the throttle into the start position. When starting the engine, place the product onto the ground in a flat clear area and hold it firmly in place so as to ensure that neither the cutting part nor the throttle come into contact with any obstacle when the engine starts. (OP5)

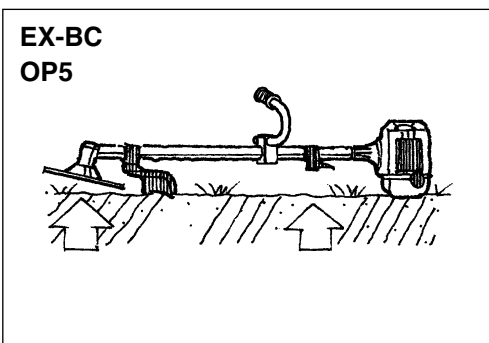

■ CUTTING METHOD

- a) Use the front left side cutting.
- b) Guide the blade from your right to left with it tilted slightly to your left. (OP6)
- c) When mowing a wide area, start working from your left end to avoid interference of cut grass.
- d) The blade may be seized by weeds if the engine speed is too low, or the blade cuts too deep into weeds. Adjust the engine speed and cutting depth according to the condition of object.

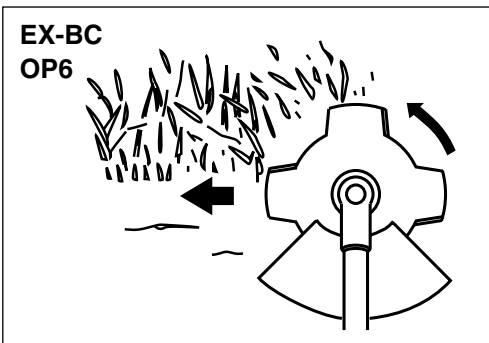

⚠ WARNING

- If the grass or other object gets caught in the blade, or if the unit starts to shake or vibrate, turn off the engine and check the whole unit. Change the blade if it has been damaged.
- Turn off the engine and make sure the blade has completely stop before checking the blade, and removing any object got caught in.

8. Operation (Optional blade usage EX-BC only)

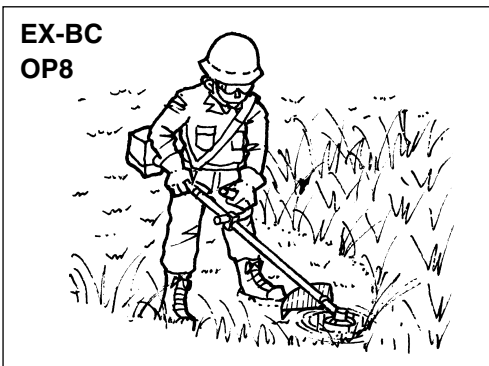
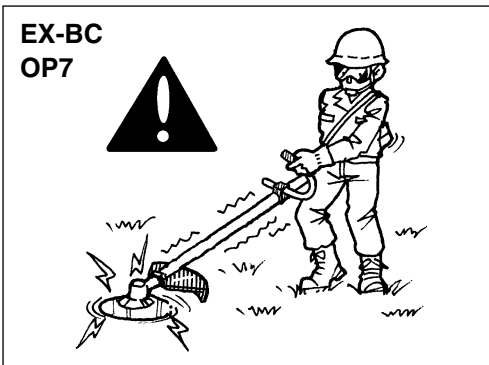

■ OPERATION

1. Check the bolt to fasten the blade and be sure the bolt has no fault, and no abrasion.
2. Be sure that the blade and the holder have been fastened according to instruction and the blade turns smoothly without abnormal noise. (OP7)

▲ WARNING

- The rotating parts fastened incorrectly may cause serious accident to the operator.
 - Make sure that the blade is not bent, warped, cracked, broken or damaged.
 - If you find any error to the blade, discard it and change new one which is certified by RedMax.
- By using the shoulder strap, hang the unit on your right side. Adjust the strap length so that the cutting head may become parallel to the ground.(OP8)

▲ WARNING

Make sure to use shoulder strap and debris guard. If not, it is vary dangerous when you slip or lose your balance.

▲ WARNING

■ CONTROLLING BLADE BOUNCE

- Kick out can cause serious personal injury. **Carefully study this section.** It is important that you understand what causes kick out, how you can reduce the chance of kick out and how you can remain in control of the unit if kick out does occur.

1. What causes kick out:

- Kick out can occur when the moving blade contacts an object that it cannot cut. This contact causes the blade to stop for an instant and then suddenly move or "bounce" away from the object that was hit. The operator can lose control of the unit and the blade can cause serious personal injury to the operator or any person nearby if the blade contacts any part of the body.

8. Operation (Optional blade usage EX-BC only)

2. How you can reduce the chance of kick out:

- a. Recognize that kick out can happen. By understanding and knowing about bounce, you can help eliminate the element of surprise.
- b. **Cut fibrous weeds and grass only.** Do not let the blade contact materials it cannot cut such as hard, woody vines and brush or rocks, fences, metal, etc
- c. Be extra prepared for bounce if you must cut where you cannot see the blade making contact such as in areas of dense growth.
- d. **Keep the blade sharp.** A dull blade increase the chance of bounce.
- e. Avoid feeding the blade too rapidly. The blade can bounce away from material being cut if the blade is fed faster than its cutting capability.
- f. Cut only from your right to your left.
- g. Keep your path of advance clear of material that has been cut and other debris.

3. How you can maintain the best control:

- a. Keep a good, firm grip on the unit with both hands. A firm grip can help neutralize bounce. Keep your right and left hands completely around the respective handles.
- b. Keep both feet spread apart in a comfortable stance and yet braced for the possibility that the unit could bounce. Do not overreach. Keep firm footing and balance.

8. Operation (Optional blade usage EX-BC only)

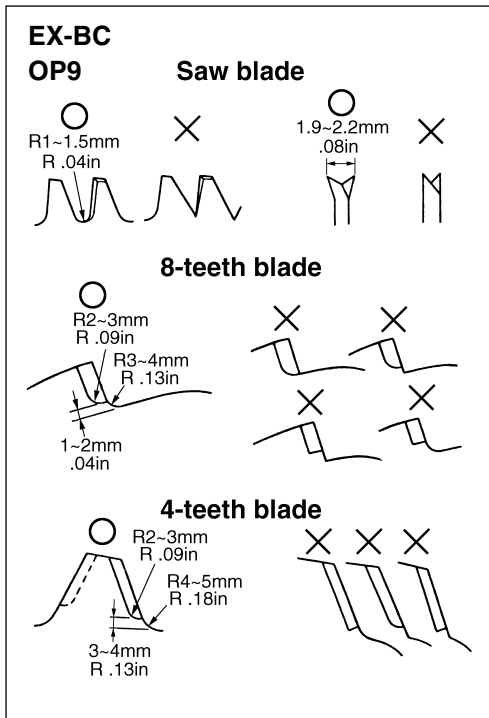

■ MAINTENANCE BLADE

- Check the blade and the fasteners for looseness, cracking, or bending.
- Check the cutting edges and reform with a flat file.

Point (OP9) :

1. Keep the end corner sharp.
2. Round the root of the edge, using round file.
3. Do not use water when using a grinder.

❗ IMPORTANT

- It is recommended that filing should be done by professionals.
- Especially regarding filing the saw blade, Leave it to the professionals.

■ TRANSPORTING THE UNIT

- When you finish cutting in one location and wish to continue work in another spot, turn off the engine, and lift up the unit and carry it paying attention to the blade.
- Never forget to place the protective cover over the blades.
- When transporting the unit over long distances, detach the blade fix the unit by ropes.

8. Operation (EX-LRT only)

⚠ WARNING

This product is equipped with extremely sharp blades, and when used improperly these blades can be extremely dangerous, and improper handling can cause accidents which may in turn lead to serious injury or death. For this reason, you should always be careful to follow the following instructions when using your trimmer.

- Never hold the trimmer in a way in which the blades are pointed towards someone else.
- Never allow the blades to come into proximity with your body while the engine of the trimmer is in operation.
- Always be sure to turn off the engine before changing the angle of the blades, removing branches which have become stuck in the blades, or at any other time when coming into close proximity with the blades.
- Always wear work gloves made of leather or some other sturdy material when using the trimmer.
- Always place the blade cover provided with the trimmer over the blades when not in use.
- **Falling branches may fall onto the face or into the eyes, resulting in injuries, scratches, and cuts, and for this reason you should always be sure to wear a helmet and face protector when using your trimmer.**



ⓘ IMPORTANT

The thickness of branches which may be cut using this trimmer is limited to up to approximately 3/16" (5mm). Never try to cut branches thicker than this, as doing so may result in damage to the trimmer.

■ ADJUSTING THE ANGLE OF THE CUTTING BLADES (OP1)

1. Stop the engine.
2. Turn the bolt located on the top of the trimming mechanism counter-clockwise to loosen it.
3. Adjust the angle of the blades to the desired angle, and then fix the bolt firmly back into place.

(1) Clamp lever

(2) Trimming mechanism

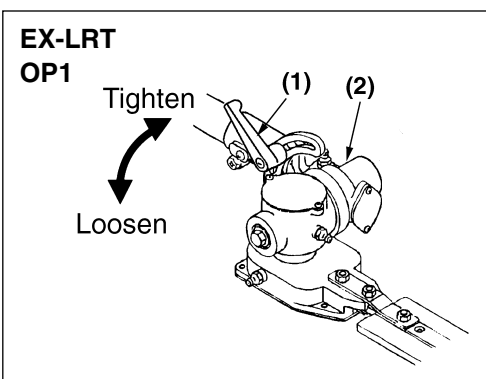

8. Operation (EX-PS only)

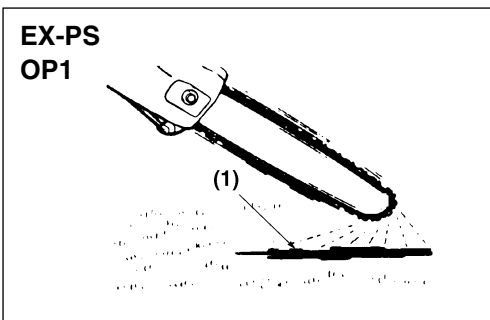

■ CHECKING OIL SUPPLY

After starting the engine, run the chain at medium speed and see if chain oil is scattered off as shown in the figure. (OP1)

(1) Chain oil

NOTE

The oil reservoir has a capacity sufficient to provide about 40 minutes of cutting time (when set to deliver the minimum flow rate, or about as long as you'll get from a tank of fuel). Be sure to refill the oil tank every time when refueling the saw.

■ ADJUSTING OIL FLOW RATE

⚠ WARNING

Never fill the oil reservoir nor adjust the oiler with the engine running.

⚠ IMPORTANT

An increase in bar oil flow rate will speed oil consumption, requiring more frequent checks on the oil reservoir. To ensure sufficient lubrication, it may be necessary to check the oil level more frequently than at fuel tank refills.

The guide bar and chain are lubricated automatically by a pump that operates whenever the chain rotates. The pump is set at the factory to deliver a minimum flow rate, but it can be adjusted in the field. A temporary increase in oil flow is often desirable when cutting things like hardwood or wood with a lot of pitch.

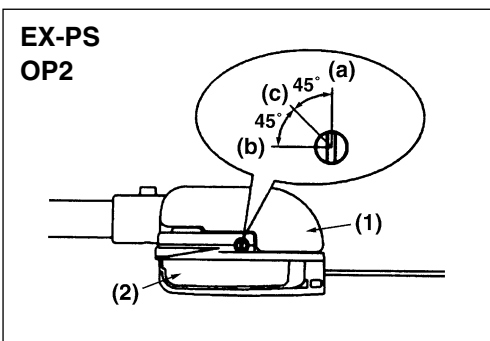

Adjust the pump as follows:

1. Stop the engine and make sure the stop switch is in the OFF position.
2. Place the unit on its side with the oil reservoir up. (OP2)

(1) Oil tank

(2) Chain cover

8. Operation (EX-PS only)

ⓘ IMPORTANT

The oil flow adjusting screw must be pressed in slightly in order to turn. Failure to do so could damage the pump and screw.

3. With a screwdriver, push in on the oil flow rate adjusting screw and turn in the desired direction (there are three incremental settings):

- (a) **Clockwise-decrease lubrication.**
- (b) **Counter clockwise-increase lubrication.**
- (c) **Middle**

⚠ WARNING

- Always wear work gloves made of leather or some other sturdy material when using the polesaw.
- **Falling branches may fall onto the face or into the eyes, resulting in injuries, scratches, and cuts, and for this reason you should always be sure to wear a helmet and face protector when using your polesaw.**



8. Operation (EX-HE only)

⚠ WARNING

- Always wear eye protection such as safety goggles. Never lean over the rotating cutting head. Rocks or other debris could be thrown into eyes and face and cause serious personal injury.
- Keep the blade guard and the mad guard attached in place at all times when the unit is operated.
- Before starting a job, check the area and remove all obstacles and objects that could be thrown by the blade.
- Do not adjust the wheel height or try to remove anything entangled to the blade with the engine running.

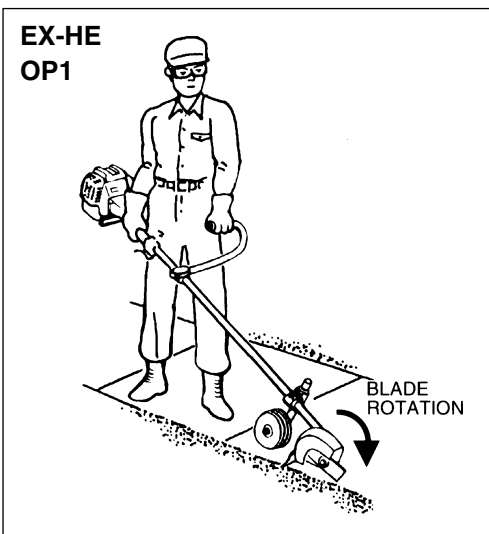

1. Before starting the engine, adjust the wheel height for desired cutting depth (See page 22).
2. Before starting a job, plan your direction of travel so that you can always hold the edger on your right side and can walk on a hard surface as much as possible.
3. When starting to edge, run the engine at full throttle, and slowly have the blade cut into the edge groove.

📖 NOTE

- Do not use the EX-HE to make a new groove into the ground. Such usage will not be covered by RedMax Warranty.

9. Maintenance

■ MAINTENANCE CHART

	system/component	procedure	before use	every 25 hours after	every 50 hours after	every 100 hours after	note
ENGINE	fuel leaks, fuel spillage	wipe out	✓				
	fuel tank, air filter, fuel filter	inspect/clean	✓	✓			replace, if necessary
	idle adjusting screw	see ■ADJUSTING IDLING SPEED (p.24)	✓				replace carburetor if necessary
	spark plug	clean and readjust plug gap			✓		GAP: .025in(0.6~0.7mm) replace, if necessary
	cylinder fins, intake air cooling vent	clean		✓			
	muffler, spark arrester, cylinder exhaust port	clean			✓		
SHAFT	throttle lever, ignition switch	check operation	✓				
	cutting parts	replace if something's wrong	✓				EX-BC, EX-LRT, EX-HE
	gear case	grease		✓			
	screws/nuts/bolts	tighten/replace	✓			✓	not adjusting screws
	debris guard	make sure to attach	✓				EX-BC, EX-HE
CUTTING UNIT	oiling port	clean	✓				EX-PS only
	guide bar	clean	✓				EX-PS only
	sprocket	inspect/replace			✓		EX-PS only
	saw chain	inspect/sharp	✓				EX-PS only

9. Maintenance

⚠ WARNING

- Make sure that the engine has stopped and is cool before performing any service to the machine. Contact with moving cutting head or hot muffler may result in a personal injury.

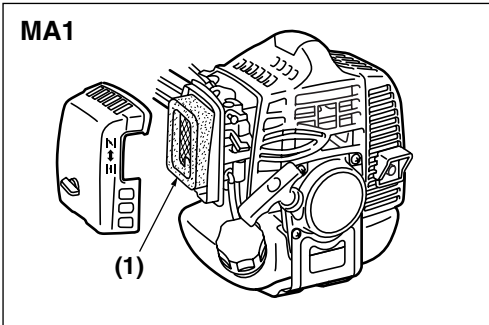

■ AIR FILTER

- The air filter, if clogged, will reduce the engine performance. Check and clean the filter element in warm, soapy water as required. Dry completely before installing. If the element is broken or shrunk, replace with a new one. (MA1)

(1) air filter

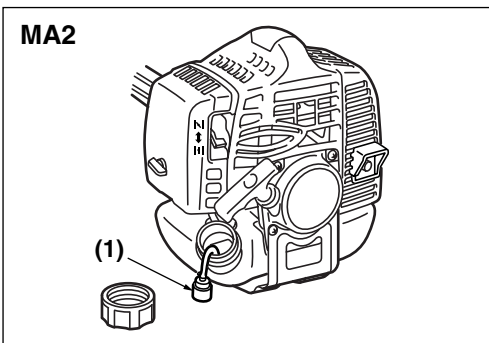

■ FUEL FILTER

- When the engine runs short of fuel supply, check the fuel cap and the fuel filter for blockage. (MA2)

(1) fuel filter

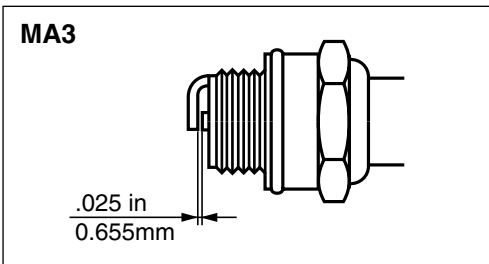

■ SPARK PLUG

- Starting failure and mis-firing are often caused by a fouled spark plug. Clean the spark plug and check that the plug gap is in the correct range. For a replacement plug, use the correct type specified by RedMax. (MA3)

• REPLACEMENT PLUG IS A NGK CMR7A.

⚠ IMPORTANT

- Note that using any spark plug other than those designated may result in the engine failing to operate properly or in the engine becoming overheated and damaged.
- To install the spark plug, first turn the plug until it is finger tight, then tighten it a quarter turn more with a socket wrench.

TIGHTENING TORQUE: 87~104 in-lbs
(9.8~11.8 N.m.)

9. Maintenance

■ MUFFLER

⚠ WARNING

- Inspect periodically, the muffler for loose fasteners, any damage or corrosion. If any sign of exhaust leakage is found, stop using the machine and have it repaired immediately.
- **Note that failing to do so may result in the engine catching on fire.**

■ SPARK ARRESTER

- The muffler is equipped with a spark arrester to prevent red hot carbon from flying out of the exhaust outlet. Periodically inspect and clean as necessary with a wire brush. In the State of California it is required by law (Section 4442 of the California Public Resources Code) to equip a spark arrester when a gas powered tool is used in any forest covered, brush covered, or grass covered unimproved land. (MA4)

(1) spark arrester

■ INTAKE AIR COOLING VENT

⚠ WARNING

- **Never touch the cylinder, muffler, or spark plugs with your bare hands immediately after stopping the engine. The engine can become very hot when in operation, and doing so could result in severe burns.**
- **When checking the machine to make sure that it is okay before using it, check the area around the muffler and remove any wood chips or leaves which have attached themselves to the brushcutter. Failing to do so could cause the muffler to become overheated, and that this in turn could cause the engine to catch on fire. Always make sure that the muffler is clean and free of wood chips, leaves, and other waste before use.**
- Check the intake air cooling vent and the area around the cylinder cooling fins after every 25 hours of use for blockage, and remove any waste which has attached itself to the

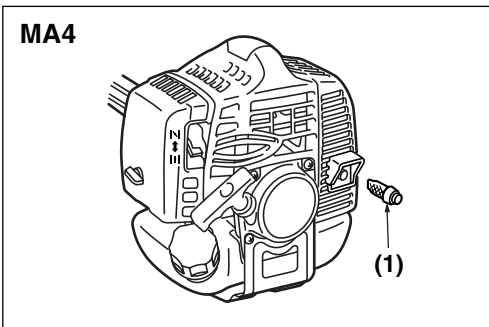

9. Maintenance

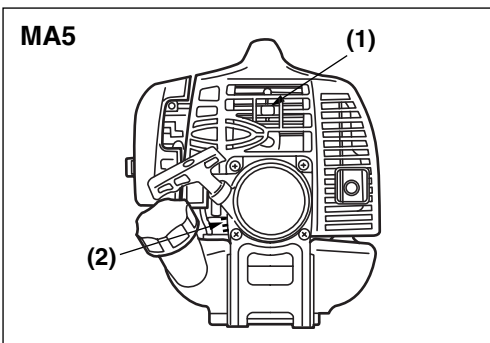

brushcutter. Note that it is necessary to remove the engine cover shown in (MA5) in order to be able to view the upper part of the cylinder.

⚠ IMPORTANT

- If waste gets stuck and causes blockage around the intake air cooling vent or between the cylinder fins, it may cause the engine to overheat, and that in turn may cause mechanical failure on the part of the brushcutter. (MA6)

(1) cylinder

(2) intake air cooling vent (back)

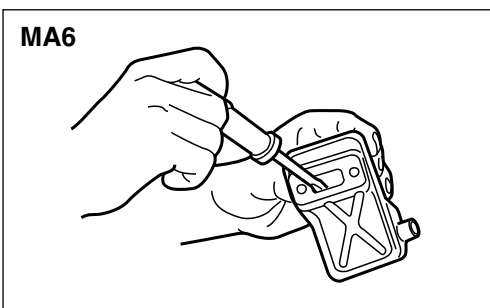

■ PROCEDURES TO BE PERFORMED AFTER EVERY 100 HOURS OF USE

1. Remove the muffler, insert a screwdriver into the vent, and wipe away any carbon buildup. Wipe away any carbon buildup on the muffler exhaust vent and cylinder exhaust port at the same time.
2. Tighten all screws, bolts, and fittings.
3. Check to see if any oil or grease has worked its way in between the clutch lining and drum, and if it has wipe it away using oil-free, lead-free gasoline.

9. Maintenance (EX-BC only)

EX-BC
MA1

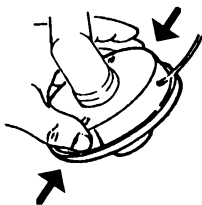

EX-BC
MA2

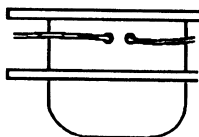

EX-BC
MA3

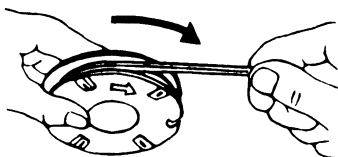

EX-BC
MA4

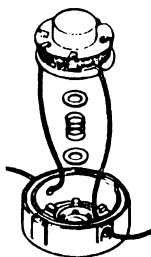

EX-BC
MA5

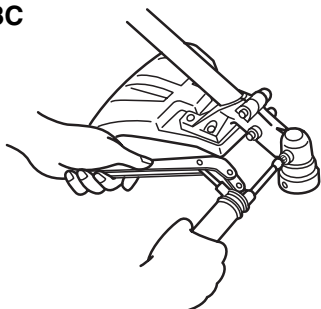

■ REFILLING TRIMMING LINE

1. For replacement line, use a diameter of .095 in(2.4mm). The spool is capable for a line upto 27ft(8m)on the 4" head, and 46ft(14m)on the 6" head. Avoid using a larger line as it may cut down the trimming performance.

▲ WARNING

For safety reasons, do not use metalreinforced line.

2. Pinch the slotted area on the both sides of the spool housing to unhook the bottom cap. (MA1)
3. Take out the spool and pull off the old line. Put one end of new line through the spool holes and pull it until the length is equal between each part of the line. (MA2)
4. Wind up the line in the correct direction as indicated on the spool. (MA3)
5. Hook each end of the line in the slot on the edge of the spool, and then put the ends through the eyelets on the housing. Make sure that the spring and the washers are in place. (MA4)
6. While holding the spool against the housing, pull the line ends to release them from the slot.
7. Line up the slot on the bottom cap with the hook on the housing, press the cap against the housing until it clicks.

■ GEAR CASE (MA5)

- The reduction gears are lubricated by multipurpose, lithium-based grease in the gear case. Supply new grease every 25 hours of use or more often depending on the job condition.
- Remove the cutter holders before installing new grease to arrange for old grease to exit.

9. Maintenance (EX-LRT only)

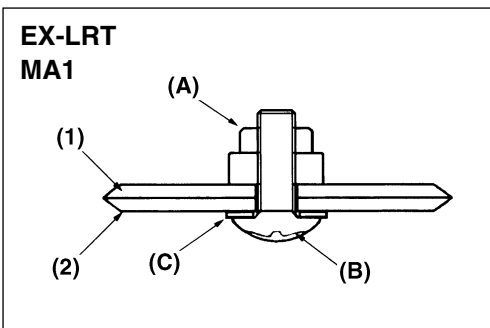

■ BLADES (MA1)

- When refilling the tank or resting, it is often a good idea to use the time to oil the cutting blades.
- If a gap exists between the upper and lower blades, follow the procedure below to adjust them so that they fit more closely together.

1. Loosen lock nut (A) as shown in the diagram.
2. Tighten screw (B) fully, and then turn one-third to one-half of a rotation backward.
3. While holding onto the screw to keep it in position, tighten the lock nut.
4. Check to make sure that the flat washer (C) is loose enough so that it may be turned by pressing on it with a finger.

(1) Upper blade

(2) Lower blade



Screwing in the screw too tightly may make it impossible for the blades to move. Conversely, not screwing in the screw tightly enough may make the blades of the trimmer feel dull and cause leaves and branches to become caught in the blades of the trimmer.

QUICK TIP

If the blades become so worn down that it is no longer possible to eliminate the gap between them, you should contact the authorized RedMax servicing dealer from which you purchased your RedMax® trimmer to have the blades resharpened or replaced.

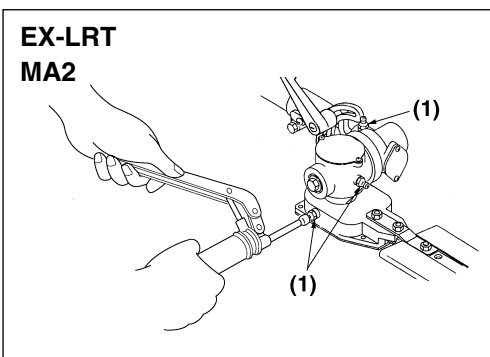

■ GEAR CASE

The reduction gears are lubricated by multipurpose, lithium-based grease in the gearcase.

Supply new grease every 25 hours of use or more often depending on the job condition.

When adding lubricant, use a grease gun to insert lubricant into the three grease nipples located on the gear case. (MA2)

(1) Grease fitting

9. Maintenance (EX-PS only)

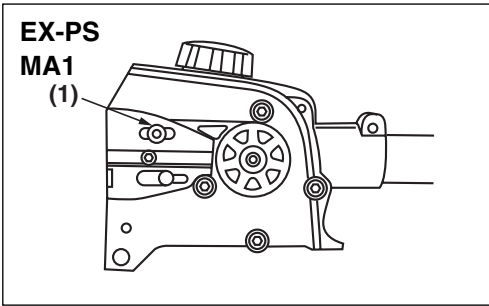

■ OILING PORT

Dismount the guide bar and check the oiling port for clogging. (MA1)

(1) Oiling port

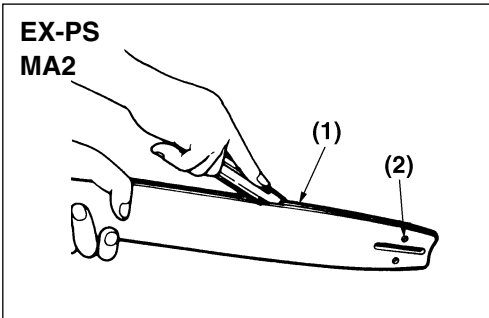

■ GUIDE BAR

Remove sawdust in the bar groove and the oiling port. (MA2)

(1) Groove

(2) Oiling port

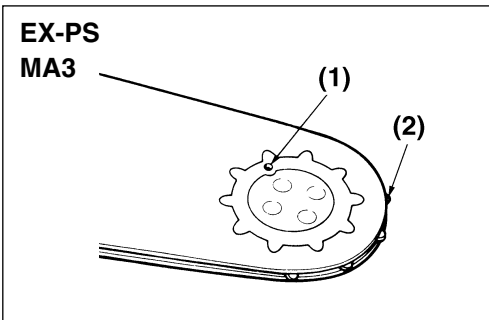

(Type: Sprocket nose)

Grease the nose sprocket from the feeding port on the tip of the bar. (MA3)

(1) Grease port

(2) Sprocket

9. Maintenance (EX-PS only)

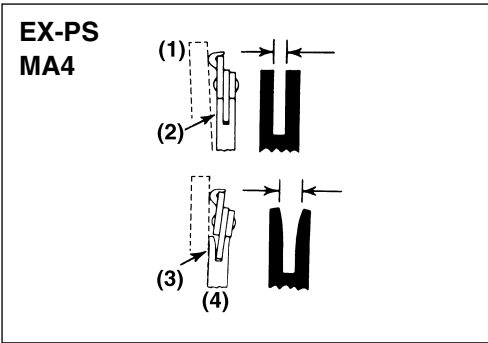

The bar rail should always be a square. Check for wear of the bar rail. Apply a ruler to the bar and the outside of a cutter. If a gap is observed between them, the rail is normal. Otherwise, the bar rail is worn. Such a bar needs to be corrected or replaced.(MA4)

- (1) Ruler
- (2) Gap
- (3) No gap
- (4) Chain tilts

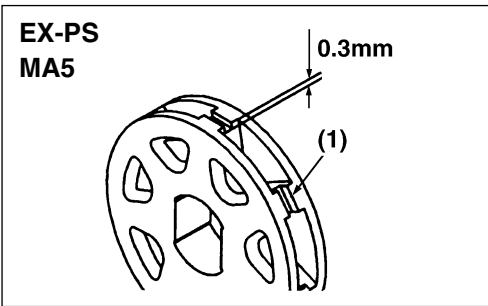

■ SPROCKET

Check for extensive wear, and replace it when the teeth are worn over 0.3mm. (MA5)

- (1) Sprocket

■ SAW CHAIN



It is very important for smooth and safe operation to keep the cutters always sharp.

Your cutters need to be sharpened when:

- Sawdust becomes powder-like.
- You need extra force to saw in.
- The cut way does not go straight.
- Vibration increases.
- Fuel consumption increases.

Cutter setting standards:



Be sure to wear safety gloves.

Before filing:

- Make sure the saw chain is held securely.
- Make sure the engine is stopped.
- Use a round file of proper size for your chain.

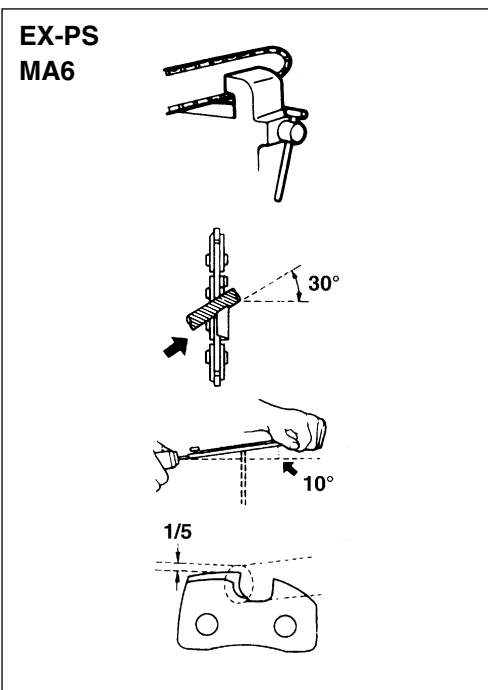

Chain type : 90SG
File size : 5/32 in (4.0mm)

Place your file on the cutter and push straight forward. Keep the file position as illustrated. (MA6)

9. Maintenance (EX-PS only)

EX-PS MA7

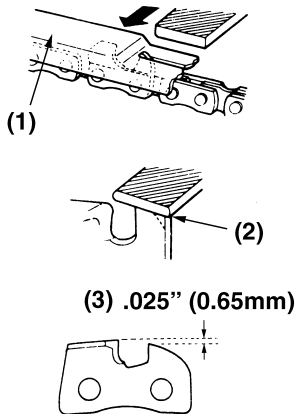

After every cutter has been set, check the depth gauge and file it to the proper level as illustrated. (MA7)

⚠ WARNING

Be sure to round off the front edge to reduce the chance of kickback or tie-strap breakage.

- (1) Appropriate gauge checker
- (2) Make the shoulder round
- (3) Depth gauge standard

EX-PS MA8

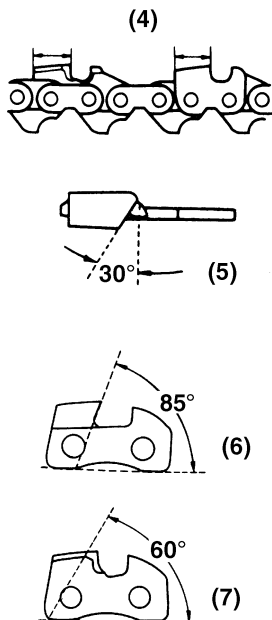

Make sure every cutter has the same length and edge angles as illustrated. (MA8)

- (4) Cutter length
- (5) Filing angle
- (6) Side plate angle
- (7) Top plate cutting angle

EX-PS MA9

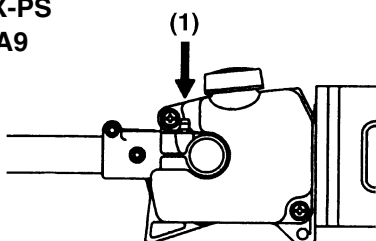

■ GEAR CASE

The reduction gears are lubricated by multipurpose, lithium-based grease in the gearcase.

Supply new grease every 25 hours of use or more often depending on the job condition.

When adding lubricant, use a grease gun to insert lubricant into the three grease nipples located on the gear case. (MA9)

- (1) Grease fitting

9. Maintenance (EX-HE only)

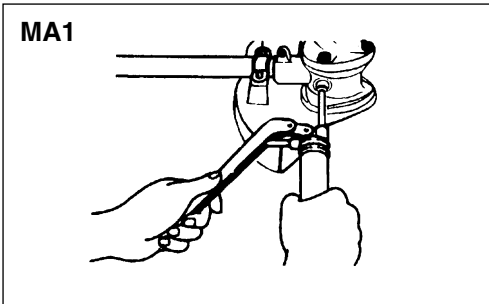

■ GEAR CASE

- The reduction gears are lubricated by multipurpose, lithium-based grease in the gear case. At every 20 hours of use, supply the gear case with new grease.
- Remove the cutter holders before installing new grease to arrange for old grease to exit.



NOTE

- When removing and installing the cutter holder(a), use care not to allow any dirt and dust entering in to the gear case.

10. Storage

- Aged fuel is one of major causes of engine starting failure. Before storing the unit, empty the fuel tank and run the engine until it uses all the fuel left in the fuel line and the carburetor. Store the unit indoor taking necessary measures for rust prevention.

11. Troubleshooting guide

Case 1. Starting failure

CHECK		PROBABLE CAUSES		ACTION
fuel tank	→	incorrect fuel	→	drain it and with correct fuel
fuel filter	→	fuel filter is clogged	→	clean
carburetor adjustment screw	→	out of normal range	→	adjust to normal range
sparkling (no spark)	→	spark plug is fouled/wet	→	clean/dry
	→	plug gap is incorrect	→	correct (GAP: 0.6~0.7mm)
spark plug	→	disconnected	→	retighten

Case 2. Engine starts but does not keep running/Hard re-starting.

CHECK		PROBABLE CAUSES		ACTION
fuel tank	→	incorrect fuel or staled fuel	→	drain it and with correct fuel
carburetor adjustment screw	→	out of normal range	→	adjust to normal range
muffler,cylinder (exhaust port)	→	carbon is built-up	→	wipe away
air cleaner	→	clogged with dust	→	wash
cylinder fin, fan cover	→	clogged with dust	→	clean

When your unit seems to need further service, please consult with our RedMax service shop in your area.

12. Parts list

EXtreme™

EXZ2500S-BC

EXZ-PU
EX-BC
ENGINE

EX-LRT (ATT)

EX-PS (ATT)

EX-HE (ATT)

NOTE :

1. Use KOMATSU ZENOAH genuine parts as specified in the parts list for repair and/or replacement.
2. KOMATSU ZENOAH does not warrant the machines, which have been damaged by the use of any parts other than those specified by the company.
3. When placing parts orders for repair and/or replacement, check if the model name and the serial number are applicable to those specified in the parts list, then use parts number described in the parts list.
4. The contents described in the parts list may change due to improvement.
5. The parts for the machine shall be supplied seven (7) years after the machine is discontinued. [It is possible that some specific parts may be subject to change of their delivery term and list price within the limit of seven (7) years after the machine is discontinued. It is also possible that some parts may be available even after the limit of seven (7) years.]

APPLICABLE SERIAL NUMBERS :

Mar. 2003

EXZ-PU	302845	and up	
EX-BC	302960	and up	
EX-LRT	000531	and up	ENGINE UNIT 352001 and up
EX-PS	000000	and up	
EX-HE	000101	and up	

12. Parts list

Fig.1 EXZ-PU (S/N 302845 and up)

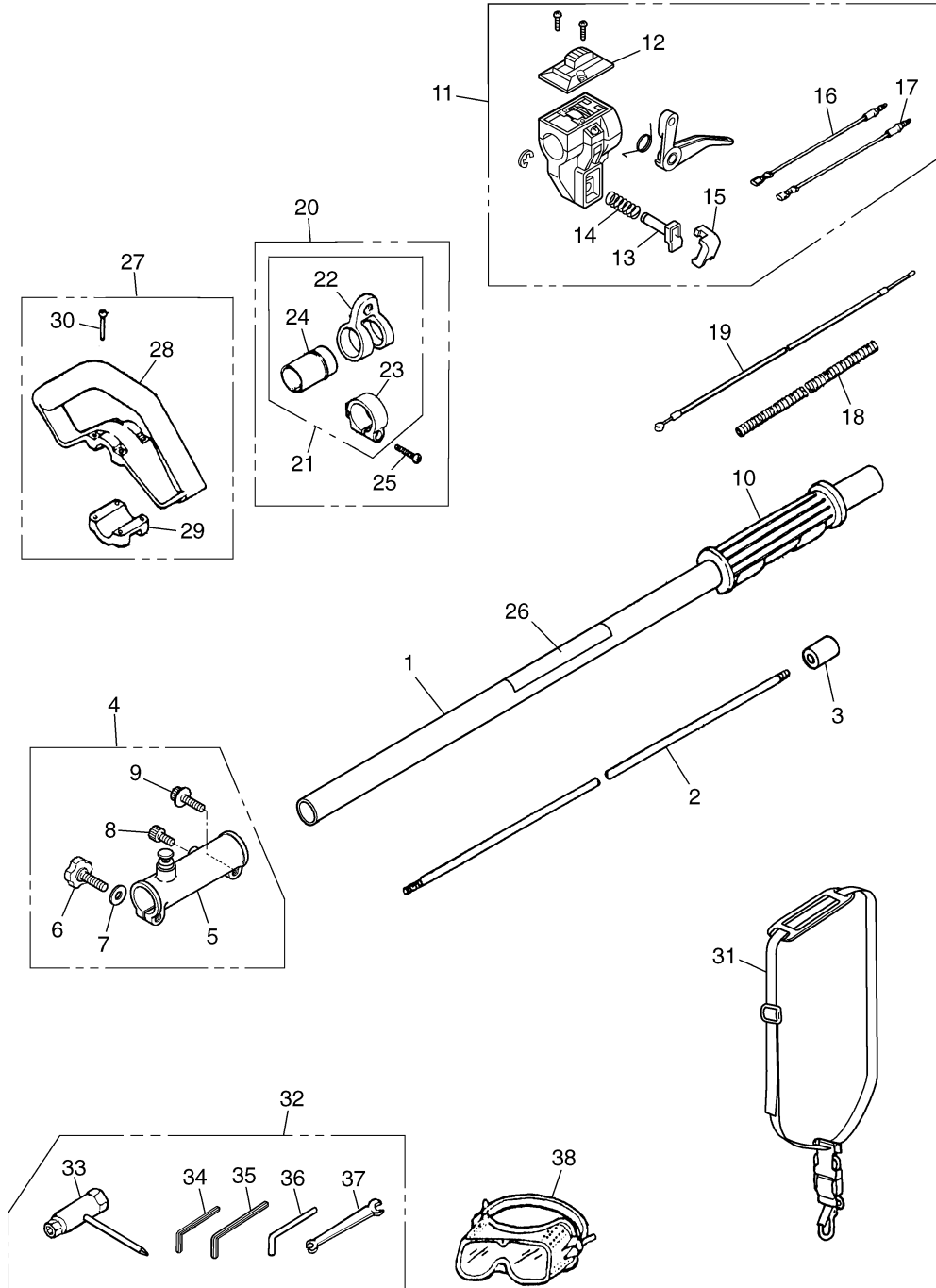

Fig.1 EXZ-PU (S/N 302845 and up)

Key#	Description	Part Number	Q'ty	Key#	Description	Part Number	Q'ty
1	PIPE-COMP, ø24x750	T3075-12100	1				
2	SHAFT, 786x7	T3075-12210	1				
3	SPACER	6036-12250	1				
4	JOINT, PIPE-ASS'Y	T3087-12400	1				
5	• JOINT	T3087-12410	1				
6	• KNOBBOLT	6036-12420	1				
7	• WASHER	01643-30823	1				
8	• BOLT	01252-30510	1				
9	• BOLT	3540-13260	1				
10	GRIP	3577-32141	1				
11	LEVER-COMP	T3002-12202	1				
12	• COVER COMP	6110-14410020	1				
13	• SHAFT	6110-14410060	1				
14	• SPRING	6110-14410080	1				
15	• BUTTON	T3032-14410090	1				
16	• CORD (A)	T3002-12220	1				
17	• CORD (B)	T3002-12230	1				
18	TUBE	T3002-12240	1				
19	CABLE	T3002-83100	1				
20	HANGER-ASSY	6420-17300	1				
21	• HANGER-COMP	6420-17400	1				
22	•• HANGER	9366-17110	1				
23	•• CLAMP	9366-17120	1				
24	•• SLEEVE	6420-17410	1				
25	• SCREW	0263-90525	1				
26	PLATE-NAME	T3087-12511	1				
27	HANDLE-ASSY	6420-14100	1				
28	• HANDLE	6420-14311	1				
29	• CLAMP	6420-14320	1				
30	• SCREW	0263-90535	4				
31	STRAP-ASSY	T3300-17100	1				
32	TOOL-SET	T3087-91000	1				
33	• SOCKET	T3039-91310	1				
34	• WRENCH	09007-00425	1				
35	• WRENCH	09007-00528	1				
36	• BAR	3540-91110	1				
37	• SPANNER	3540-91120	1				
38	GOGGLE	T3002-91190	1				

12. Parts list

Fig.2 EX-BC (S/N 302960 and up)

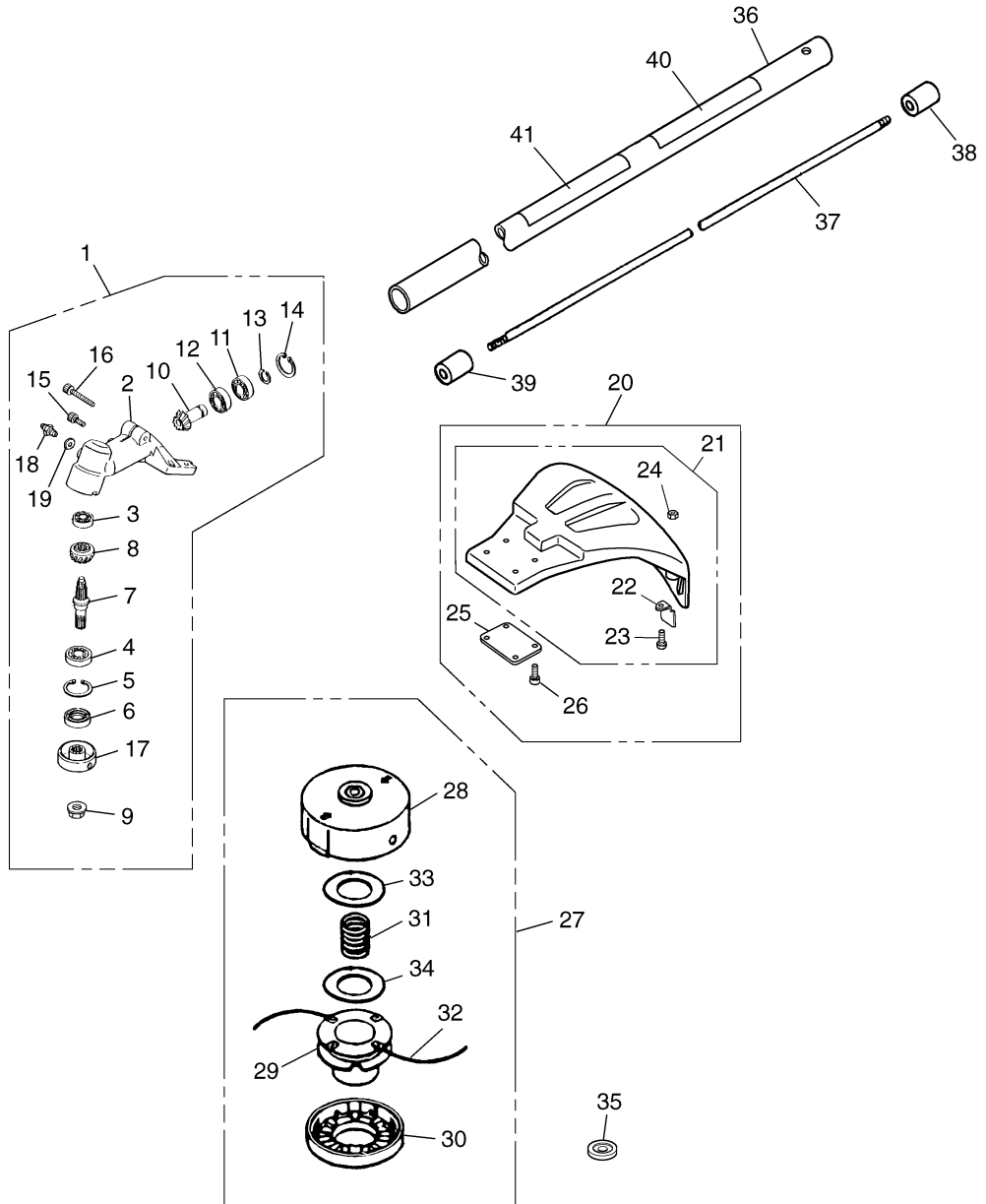

Fig.2 EX-BC (S/N 302960 and up)

Key#	Description	Part Number	Q'ty	Key#	Description	Part Number	Q'ty
1	GEARCASE-ASSY	T3002-13001	1				
2	• GEARCASE	6489-13110	1				
3	• BEARING	T3300-13521	1				
4	• BEARING	T3403-13510	1				
5	• RING	04065-02612	1				
6	• SEAL	3565-13130	1				
7	• SHAFT	T3002-13210	1				
8	• GEAR	6440-13220	1				
9	• NUT, M10	T3002-13260	1				
10	• PINION	T3002-13310	1				
11	• BEARING	T3300-13531	1				
12	• BEARING	T3403-13530	1				
13	• RING	T3300-13330	1				
14	• RING	04065-02412	1				
15	• BOLT	01252-30510	1				
16	• BOLT	3350-21320	1				
17	• HOLDER (A)	6440-13242	1				
18	• FITTING, grease	3199-13350	1				
19	• WASHER	01641-20608	1				
20	GUARD-ASSY	T3002-24001	1				
21	• GUARD COMP	T3002-24101	1				
22	•• BLADE	T3002-24121	1				
23	•• SCREW	0263-90516	1				
24	•• NUT	3320-15310	1				
25	• PLATE	6489-24120	1				
26	• BOLT	01252-30514	4				
27	TAP. HEAD 4"	PT104	1				
28	• CASE	6460-15123	1				
29	• CORD HOLDER	6460-15142	1				
30	• COVER	6460-15131	1				
31	• SPRING	6041-99162	1				
32	• TRIMMER LINE	6460-15180	1				
33	• PLATE, large	3268-15150	1				
34	• PLATE, small	3268-15170	1				
35	HOLDER (B)	6019-13250	1				
36	PIPE-COMP, ø24x750	T3102-12100	1				
37	SHAFT, 755x7	T3102-12210	1				
38	SHAFT-JOINT	6036-12241	1				
39	SPACER	6036-12250	1				
40	PLATE-NAME	T3102-12510	1				
41	PLATE	6425-12552	1				

12. Parts list

Fig.3 ENGINE UNIT (352001 and up)

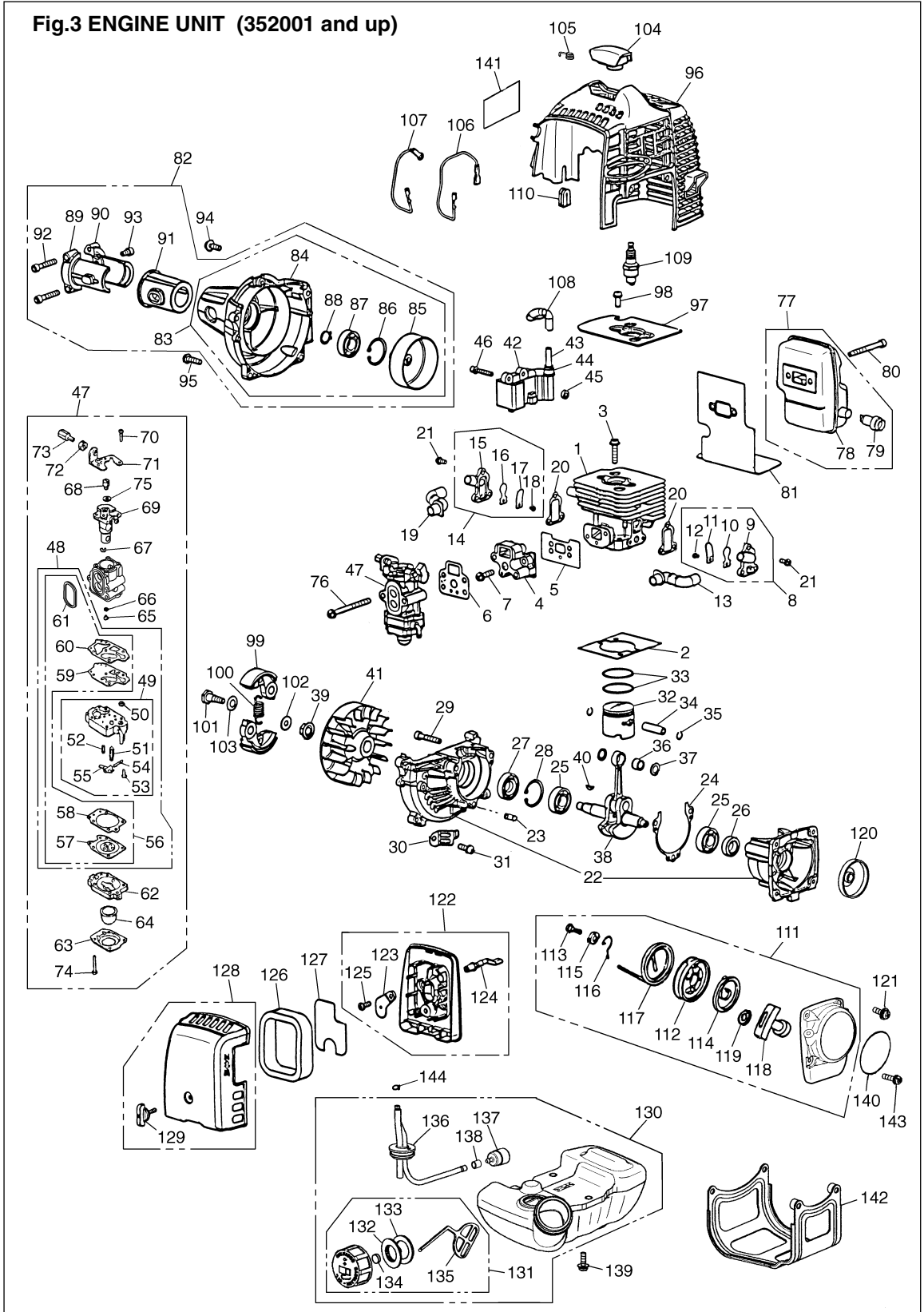

Fig.3 ENGINE UNIT (352001 and up)

Key#	Description	Part Number	Q'ty	Key#	Description	Part Number	Q'ty
1	CYLINDER	4810-12111	1	73	• SCREW, adjuster	1918-81170	1
2	GASKET, base	4810-12210	1	74	• SCREW	1850-81530	4
3	BOLT, M5x22	1850-12130	2	75	• WASHER	5500-81160	1
4	INSULATOR	4810-13162	1	76	SCREW, M5x60	0263-90560	2
5	GASKET, insulator	4810-13120	1	77	MUFFLER ASS'Y	4810-15100	1
6	GASKET, carburetor	4810-13130	1	78	• MUFFLER	4810-15111	1
7	SCREW, M5x20	0263-90520	1	79	• ARRESTER	4810-15140	1
8	REEDVALVE (S)-A	4810-16100	1	80	BOLT, M5x50	01252-30550	2
9	• VALVECASE (S)	4810-16110	1	81	GASKET	T1501-15211	1
10	• REEDVALVE	4810-16120	1	82	COVER-A	4810-31001	1
11	• STOPPER	4810-16130	1	83	• COVER-C	4810-31101	1
12	• SCREW, M3x8	4810-16170	1	84	•• COVER, fan	4810-31110	1
13	PIRE AIR (S)	4810-16150	1	85	•• DRUM	4810-31122	1
14	REEDVALVE (F)-A	4810-16200	1	86	•• SNAPRING	04065-02812	1
15	• VALVECASE (F)	4810-16210	1	87	•• BEARING	06002-06001	1
16	• REEDVALVE	4810-16120	1	88	•• SNAP RING	04064-01210	1
17	• STOPPER	4810-16130	1	89	• BRACKET (A)	6470-31211	1
18	• SCREW, M3x8	4810-16170	1	90	• BRACKET (B)	6470-31221	1
19	PIPE AIR (F)	4810-16160	1	91	• CUSHION	6470-31230	1
20	GASKET, valve	4810-16140	2	92	• BOLT, M5x30	01252-30530	2
21	SCREW	4810-16180	6	93	• BOLT, M5x14	01252-30514	1
22	CRANKCASE-C	4810-21101	1	94	SCREW, M5x16	5500-85510	1
23	• PIN	2629-21130	3	95	SCREW, M5x20	0263-90520	4
24	GASKET	4810-21140	1	96	COVER, engine	4810-32111	1
25	BEARING	06030-06001	2	97	PLATE	T1501-12310	1
26	SEAL	4810-21210	1	98	SCREW, M5x10	0263-90510	2
27	SEAL	1850-21220	1	99	SHOE	4820-51110	2
28	SNAP RING	04065-02812	1	100	SPRING	4820-51220	1
29	BOLT, M5x30	01252-30530	3	101	SCREW	1140-51250	2
				102	WASHER	1140-51230	2
				103	WASHER	1140-51242	2
32	PISTON	4810-41110	1	104	CAP	4810-72111	1
33	RING	5910-41210	2	105	SPRING	1900-72120	1
34	PIN	T1513-41310	1	106	CORD	4810-71240	1
35	RING	1260-41320	2	107	CORD, carth	4810-71250	1
36	BEARING	5500-41410	1	108	TUBE	T1512-71320	1
37	WASHER	1101-41340	2	109	PLUG, NGK CMR7A	4810-73110	1
38	CRANKSHAFT-C	4810-42000	1	110	GROMMET	4810-72120	1
39	NUT	1650-43230	1	111	RECOIL ASS'Y	4810-75100	1
40	KEY	1000-43240	1	112	• REEL	4500-75120	1
41	ROTOR	4810-71110	1	113	• SCREW	4500-75150	1
42	COIL-A	T1512-71200	1	114	• SPRING, spiral	1850-75130	1
43	• CORD	T1512-71220	1	115	• COLLAR	4500-75180	1
44	• CAP	2616-71320	1	116	• ARM	4500-75190	1
45	SPACER	1260-71261	2	117	• ROPE	4810-75160	1
46	BOLT	4500-72150	2	118	• KNOB	3330-75421	1
47	CARBURETOR ASS'Y, WYA-1D	4810-81002	1	119	• PLATE, stopper	4810-75170	1
48	• REBUILD KIT	T1551-06030	1	120	PULLEY	4500-75210	1
49	•• BODY ASS'Y	T1551-81450	1	121	SCREW	5500-85510	2
50	••• SCREEN	—	—	122	BODY ASS'Y	4810-82100	1
51	••• VALVE	—	—	123	• PLATE, choke	4810-82130	1
52	••• SPRING	—	—	124	• LEVER, choke	5500-82140	1
53	••• SCREW	—	—	125	• SCREW	2630-33610	1
54	••• PIN	—	—	126	ELEMENT	4810-82170	1
55	••• LEVER	—	—	127	SCREEN	4810-82180	1
56	•• GASKET KIT	4810-06021	1	128	COVER ASS'Y	4810-82200	1
57	••• DIAPHRAGM	—	—	129	• KNOB	5500-82221	1
58	••• GASKET, diaphragm	—	—	130	TANK ASS'Y	T1504-85002	1
59	••• DIAPHRAGM, pump	—	—	131	• CAP ASS'Y	T1015-85202	1
60	••• GASKET, pump	—	—	132	•• HOLDER-A	4500-85300	1
61	••• RING	4810-81130	1	133	•• PACKING	4500-85220	1
62	• BODY, purge	1850-81490	1	134	•• FILTER	5601-85260	1
63	• COVER, pump	1850-81520	1	135	•• STOPPER	4820-85260	1
64	• PUMP, priming	1751-81510	1	136	• PIPE COMP.	4810-85300	1
65	• JET, #38.5	4810-81251	1	137	• FLTER ASS'Y	3302-85400	1
66	• O-RING	1751-81240	1	138	• COLLER	2841-31280	1
67	• RING	1751-81130	1	139	SCREW, M5x16	5500-85510	3
68	• SWIVEL	1881-81140	1	140	LABEL, recoil	—	—
69	• VALVE ASS'Y	—	—	141	LABEL, cover	4810-31132	1
70	• SCREW	1752-81110	2	142	GUARD	T1506-31910	1
71	• BRACKET	5500-81120	1	143	SCREW	0263-90525	2
72	• NUT, adjuster	1751-81180	1	144	CLIP	1950-86120	1

12. Parts list

Fig.4 EX-LRT (S/N 000531 and up)

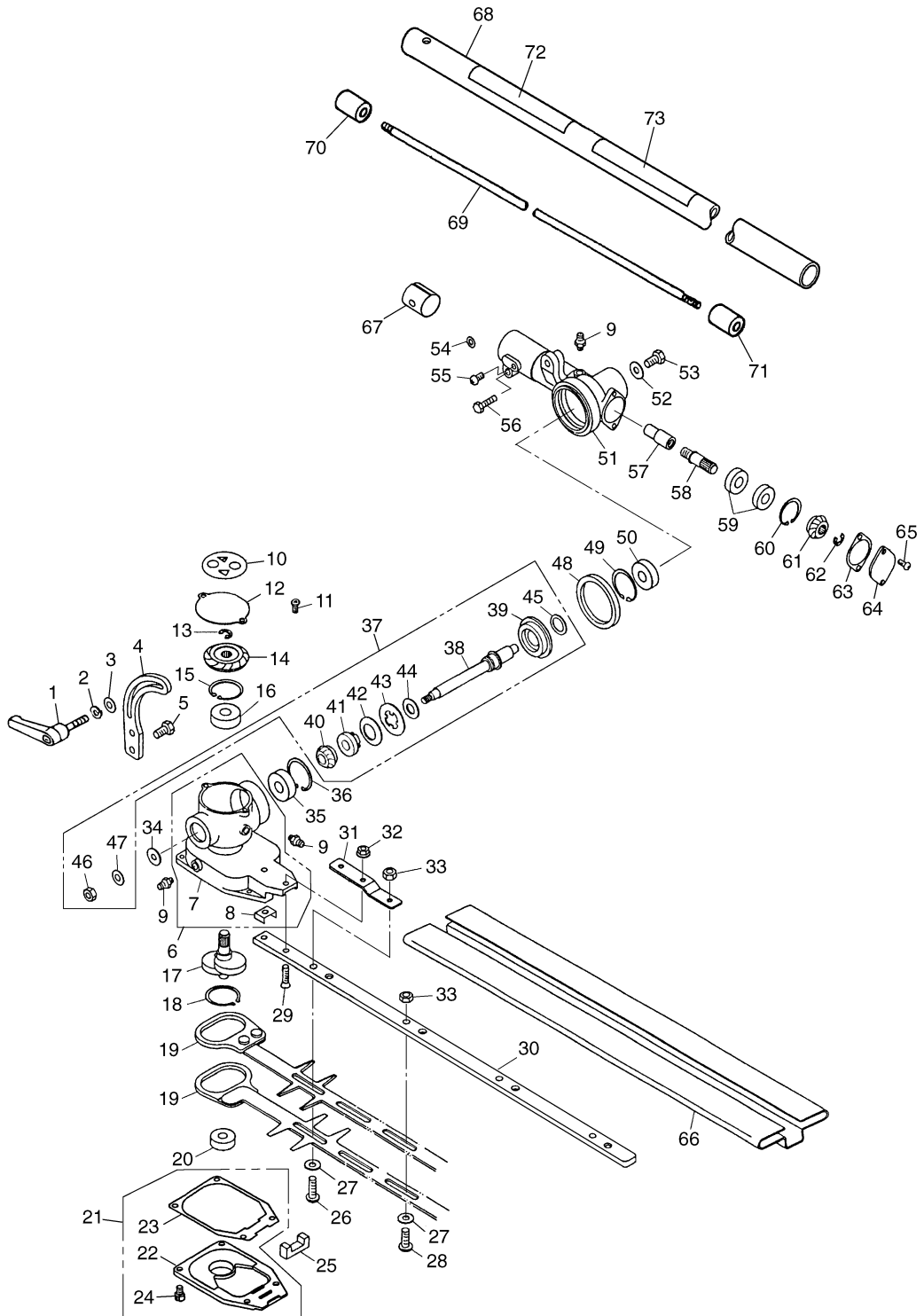

Fig.4 EX-LRT (S/N 000531 and up)

Key#	Description	Part Number	Q'ty	Key#	Description	Part Number	Q'ty
1	LEVER, clamp	6598-13110	1	53	BOLT M6x12	0225-10612	1
2	WASHER M6	0290-20615	1	54	WASHER 5x10x1.0	6782-13720	1
3	WASHER 6x15x2.0	6782-13650	1	55	BOLT M5x10	01252-30510	1
4	ANGLE ADJUSTER	6782-13141	1	56	BOLT M5x30	3350-21320	1
5	BOLT M6x12	0225-10612	2	57	JOINT	6782-13810	1
6	CASING A SET	6782-13200	1	58	GEAR SHAFT B	6598-13820	1
7	• CASING A	_____	1	59	BEARING 6900RS	6782-13830	2
8	• PLATE	6782-13220	1	60	SNAP RING	04065-02212	1
9	GREASE FITTING	3199-13350	3	61	BEVEL GEAR	6782-13850	1
10	LABEL	6782-13250	1	62	SNAP RING	6598-13330	1
11	SCREW M4x8	0263-10408	2	63	PACKING	6598-13860	1
12	COVER	6598-13320	1	64	COVER	6598-13870	1
13	SNAP RING	6598-13330	1	65	SCREW M4x8	0263-10408	2
14	BEBEL GEAR	6782-13340	1	66	BLADE COVER	6782-13910	1
15	SNAP RING	04065-02612	1	67	SPACER	6367-13990	1
16	BEARING	06004-06000	1	68	PIPE-COMP, \varnothing 24x750	T3102-12100	1
17	CRANK SHAFT	6782-13370	1	69	SHAFT, 755x7	T3102-12210	1
18	SNAP RING	04064-02815	1	70	SHAFT-JOINT	6036-12241	1
19	BLADE	6782-13411	2	71	SPACER	6036-12250	1
20	BEARING 608Z	6782-13430	1	72	PLATE-NAME	T3103-12511	1
21	COVER ASS'Y	6782-06010	1	73	PLATE	6425-12552	1
22	• COVER	6782-13441	1				
23	• GASKET	6782-13470	1				
24	• BOLT, M4x12	6783-13450	4				
25	FELT	6782-13460	1				
26	SCREW	3884-11750	1				
27	WASHER	3880-11780	4				
28	SCREW L17	6598-13510	3				
29	SCREW M5x20	6598-13530	2				
30	GUIDE PLATE	6782-13540	1				
31	PLATE	6782-13550	1				
32	NUT M5	6782-14470	2				
33	NUT M6	3880-11790	4				
34	WASHER 6x15x2.0	6782-13650	1				
35	BEARING 608 2RS	6598-13430	1				
36	SNAP RING	04065-02212	1				
37	SHAFT KIT	T4008-06010	1				
38	•• SHAFT	_____	1				
39	•• GEAR(B)	_____	1				
40	•• GEAR(C)	T4008-13630	1				
41	•• BOSS	_____	1				
42	•• SPRING	T4008-13650	1				
43	•• PLATE	T4008-13660	1				
44	•• WASHER	T4008-13670	1				
45	•• WASHER	T4008-13680	1				
46	• NUT M6	0280-10605	1				
47	• WASHER	0290-20615	1				
48	O-RING P41	6598-13620	1				
49	SNAP RING	04065-02612	1				
50	BEARING	06004-06000	1				
51	CASING B	6782-13710	1				
52	WASHER 6x15x2.0	6782-13650	1				

12. Parts list

Fig.5 EX-PS (S/N 000000 and up)

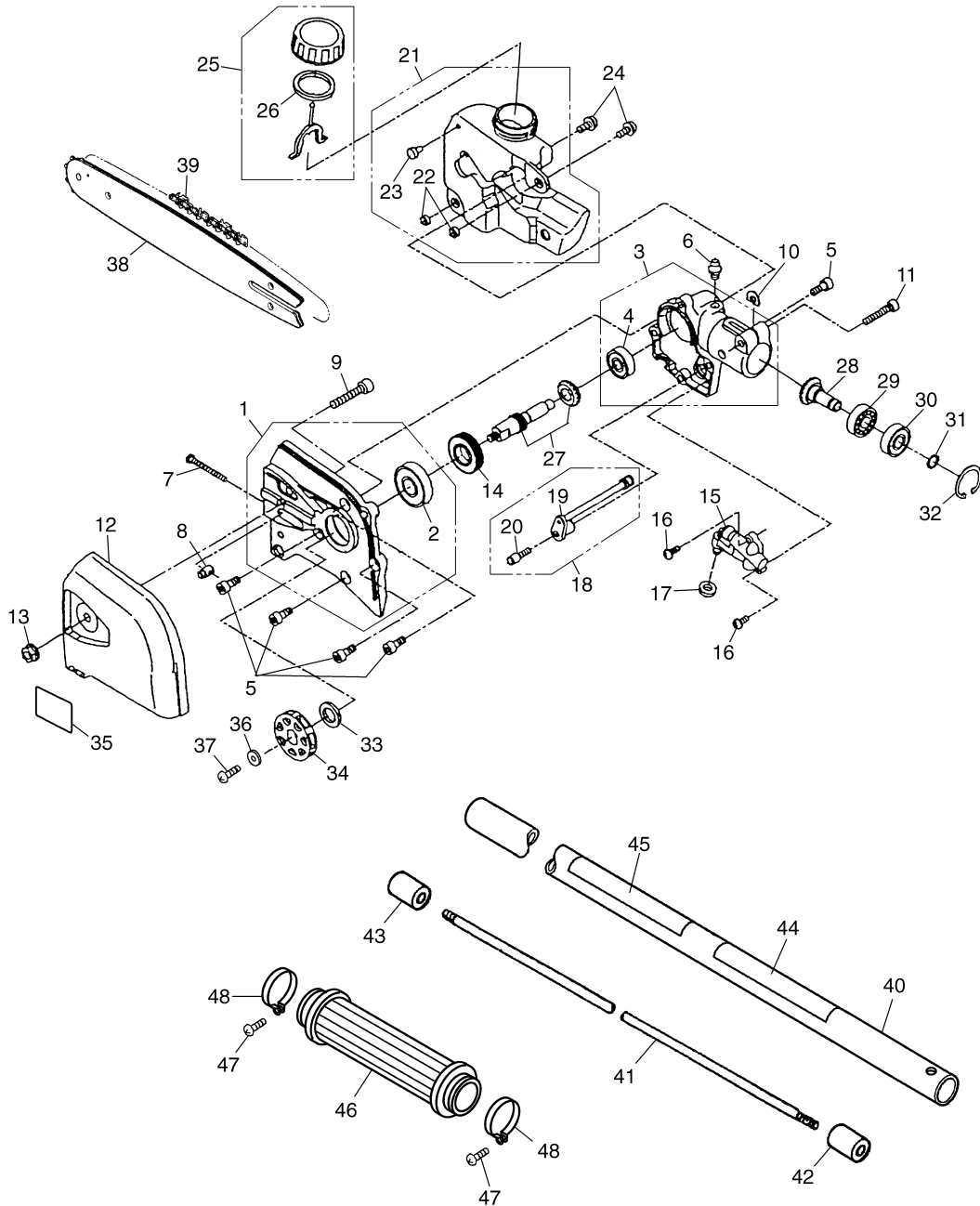

Fig.5 EX-PS (S/N 000000 and up)

Key#	Description	Part Number	Q'ty	Key#	Description	Part Number	Q'ty
1	GEAR CASE (L)COMP	T3073-13100	1	47	CLAMP	6193-11340	2
2	• BEARING	06004-06001	1	48	SCREW	0260-60312	2
3	GEAR CASE (R)COMP	T3073-13200	1				
4	• BEARING	06002-00627	1				
5	BOLT	01252-30512	5				
6	FITTING	3199-13350	1				
7	SCREW, tensioner	T3073-13310	1				
8	NUT, tensioner	T3073-13320	1				
9	BOLT	01252-30630	1				
10	SHIM	T3073-13250	1				
11	BOLT	3245-11350	1				
12	CHAIN COVER	T3073-13510	1				
13	NUT	T3073-13520	1				
14	WORM GEAR	T3073-13560	1				
15	OIL PUMP ASS'Y	T3073-13550	1				
16	SCREW	0263-30410	2				
17	GASKET	T3073-13580	1				
18	OIL PIPE ASS'Y	T3073-13700	1				
19	• OIL PIPE	T3073-13710	1				
20	• FILTER	T3073-13720	1				
21	OIL TANK ASS'Y	T3073-13800	1				
22	• COLLAR	T3073-13820	2				
23	• VALVE	T3073-13830	1				
24	SCREW	T3073-13860	2				
25	OIL CAP ASS'Y	T3073-13900	1				
26	• GASKET OIL CAP	T3073-13920	1				
27	GEAR SHAFT	T3073-13370	1				
28	BEVEL, pinion	T3073-13380	1				
29	BEARING	06000-00609	1				
30	BEARING	06002-00609	1				
31	SNAP RING	3210-13330	1				
32	SNAP RING	04065-02412	1				
33	COLLAR	T3073-13530	1				
34	SPROCKET	T3073-13540	1				
35	LABEL	T3073-13590	1				
36	WASHER	T3073-13350	1				
37	SCREW	T3073-13360	1				
38	BAR 12" (OREGON)	109666	1				
39	CHAIN (OREGON)	90SG44X	1				
40	PIPE-COMP, ø24x750	T3102-12100	1				
41	SHAFT, 755x7	T3102-12210	1				
42	SHAFT-JOINT	6036-12241	1				
43	SPACER	6036-12250	1				
44	PLATE-NAME	T3104-12511	1				
45	PLATE	6425-12552	1				
46	GRIP	6442-11332	1				

12. Parts list

Fig.6 EX-HE (S/N 000101 and up)

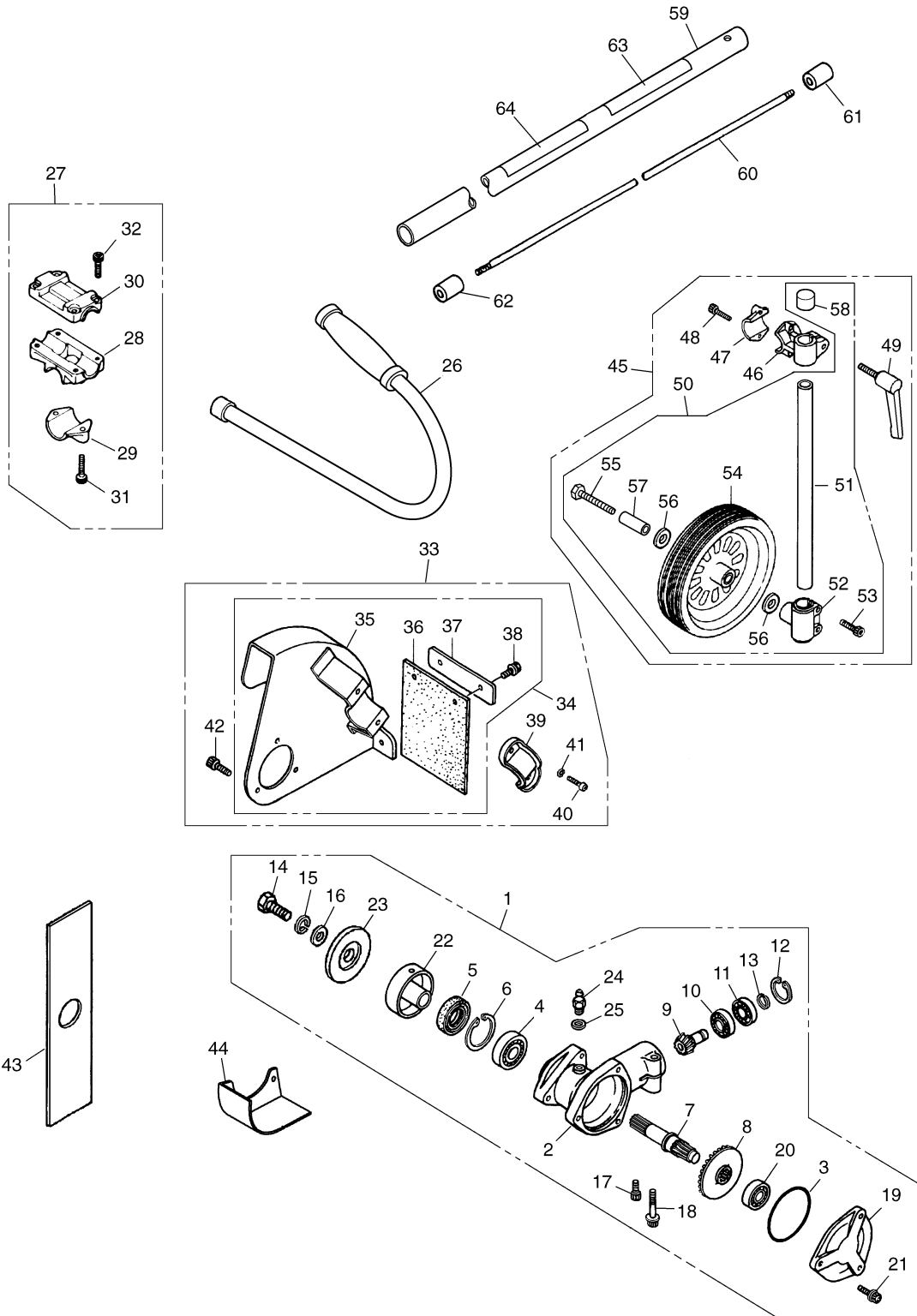

Fig.6 EX-HE (S/N 000101 and up)

Key#	Description	Part Number	Q'ty	Key#	Description	Part Number	Q'ty
1	GEARCASE-ASS'Y	6367-13000	1	51	•• PIPE	6367-15210	1
2	• GEARCASE	6367-13110	1	52	•• BRACKET	3808-15230	1
3	• O-RING	6367-13150	1	53	•• BOLT	01252-30625	2
4	• BEARING	06000-06201	1	54	•• WHEEL	T3052-25150	1
5	• SEAL	3180-13141	1	55	•• BOLT	01010-81055	1
6	• RING	04065-03212	1	56	•• WASHER	01642-21016	2
7	• SHAFT	3541-13212	1	57	•• PIPE	T3052-25160	1
8	• GEAR	6367-13130	1	58	•• CAP	T3052-15250	1
9	• PINION	6367-13140	1	59	PIPE-COMP, ϕ 24x750	T3105-12100	1
10	• BEARING	06000-00609	1	60	SHAFT, 755x7	T3102-12210	1
11	• BEARING	06001-00609	1	61	SHAFT-JOINT	6036-12241	1
12	• RING	04065-02412	1	62	SPACER	6036-12250	1
13	• RING	3210-13330	1	63	PLATE-NAME	T3105-12511	1
14	• BOLT	3579-33260	1	64	PLATE	6425-12552	1
15	• WASHER	3310-43210	1				
16	• WASHER	01643-30823	1				
17	• BOLT	01252-30512	1				
18	• BOLT	3540-13260	1				
19	• COVER	6367-13120	1				
20	• BEARING	06000-06000	1				
21	• BOLT	3350-31470	3				
22	• HOLDER (A)	3541-13241	1				
23	• HOLDER (B)	3541-13251	1				
24	• FITTING	3199-13350	1				
25	• WASHER	01641-20608	1				
26	HANDLE-COMP	6367-14200	1				
27	BRACKET-ASS'Y	3583-14101	1				
28	• BRACKET	3583-14111	1				
29	• CAP-L	3583-14121	1				
30	• CAP-U	3257-14192	1				
31	• BOLT	01252-30522	2				
32	• BOLT	01252-30525	4				
33	GUARD-ASS'Y	6367-24001	1				
34	• GUARD-COMP	6367-24101	1				
35	•• GUARD	6367-24111	1				
36	•• PLATE	6367-24120	1				
37	•• PLATE	6367-24131	1				
38	•• BOLT	0225-30512	2				
39	• CLAMP	5807-24120	1				
40	• BOLT	01252-30618	2				
41	• WASHER	0290-20615	2				
42	• BOLT	3350-31470	3				
43	BLADE	6367-15110	1				
44	COVER	T3052-13610	1				
45	WHEEL-ASS'Y	T3052-25001	1				
46	• BRACKET	6367-15230	1				
47	• CAP-L	3583-14121	1				
48	• BOLT	01252-30522	2				
49	• LEVER	3956-15340	1				
50	• WHEEL-S-ASS'Y	T3052-25101	1				

CALIFORNIA EMISSION CONTROL WARRANTY STATEMENT
YOUR WARRANTY RIGHTS AND OBLIGATIONS

The California Air Resources Board and KOMATSU ZENOAH are pleased to explain the **emission control system warranty** on your **1995 and later** small off-road engine. In California, new small off-road engines must be designed, built and equipped to meet the state's stringent anti-smog standards. KOMATSU ZENOAH must warrant the emission control system on your small off-road engine for the periods of time listed below provided there has been no abuse, neglect or improper maintenance of your small off-road engine.

Your emission control system may include parts such as the carburetor and the ignition system.

Where a warrantable condition exists, KOMATSU ZENOAH will repair your small off-road engine at no cost to you including diagnosis, parts and labor.

Manufacturer's warranty coverage:

The 1995 and later small off-road engines are warranted for **two years**. If any emission-related part on your engine is defective, the part will be repaired or replaced by KOMATSU ZENOAH.

Owner's warranty responsibilities:

– As the small off-road engine owner, you are responsible for the performance of the **required maintenance listed in your owner's manual**. KOMATSU ZENOAH recommends that you retain all receipts covering maintenance on your small off-road engine, but KOMATSU ZENOAH can not deny warranty solely for the lack of receipts or for your failure to ensure the performance of all scheduled maintenance.

– As the small off-road engine owner, you should be aware, however, that KOMATSU ZENOAH may deny you warranty coverage if your small off-road engine or a part has failed due to abuse, neglect, improper maintenance or unapproved modification.

– You are responsible for presenting your small off-road engine to a KOMATSU ZENOAH distribution center as soon as a problem exists. The warranty repairs should be completed in a reasonable amount of time, not to exceed **30 days**.

If you have any questions regarding your warranty rights and responsibilities, you should contact KOMATSU ZENOAH AMERICA INC. at (770)-381-5147 or you can write to

KOMATSU ZENOAH AMERICA INC.
4344 Shackleford Road Suite 500
Norcross, Georgia 30093

RedMax 2-YEAR LIMITED WARRANTY

EMISSION-RELATED PARTS, FOR TWO (2) YEARS FROM THE DATE OF ORIGINAL DELIVERY, KOMATSU ZENOAH AMERICA INC. (THE COMPANY), THROUGH ANY RedMax DEALER, WILL REPAIR OR REPLACE, FREE OF CHARGE, FOR THE ORIGINAL AND EACH SUBSEQUENT PURCHASER, ANY PART OR PARTS FOUND TO BE DEFECTIVE IN MATERIAL AND/OR WORKMANSHIP. EMISSION-RELATED PARTS ARE:

**THE CARBURETOR ASSY, COIL ASSY, ROTOR, SPARKPLUG,
AIR FILTER, FUEL FILTER, INTAKE MANIFOLD, AND THE GASKETS**

ALL OTHER PARTS EXCEPT ABOVE PARTS, FOR TWO (2) YEARS OF HOME USE [ONE (1) YEAR FOR ANY OTHER USE] FROM THE DATE OF ORIGINAL ANY DELIVERY, THE COMPANY. THROUGH ANY RedMax DEALER, WILL REPAIR OR REPLACE, FREE OF CHARGE, FOR THE ORIGINAL PURCHASER, ANY PART OF PARTS FOUND TO BE DEFECTIVE IN MATERIAL AND/OR WORKMANSHIP. **THIS IS THE EXCLUSIVE REMEDY.**

THE PURCHASER SHALL BEAR COSTS OF TRANSPORTING THE UNIT TO AND FROM THE RedMax DEALER.

THE PURCHASER SHALL NOT BE CHARGED FOR DIAGNOSTIC LABOR WHICH LEADS TO THE DETERMINATION THAT A WARRANTED PART IS DEFECTIVE, IF THE DIAGNOSTIC WORK IS PERFORMED AT THE RedMax DEALER.

THE PURCHASER OR OWNER IS RESPONSIBLE FOR THE PERFORMANCE OF THE REQUIRED MAINTENANCE AS DEFINED BY THE MANUFACTURER IN THE OWNER/OPERATOR MANUAL.

ANY WARRANTED PART WHICH IS NOT SCHEDULED FOR REPLACEMENT AS REQUIRED MAINTENANCE, OR WHICH IS SCHEDULED ONLY FOR REGULAR INSPECTION TO THE EFFECT OF "REPAIR OR REPLACE AS NECESSARY" SHALL BE WARRANTED FOR THE WARRANTY PERIOD. ANY WARRANTED PART WHICH IS SCHEDULED FOR REPLACEMENT AS REQUIRED MAINTENANCE SHALL BE WARRANTED FOR THE PERIOD OF TIME UP TO THE FIRST SCHEDULED REPLACEMENT POINT FOR THE PART.

ANY REPLACEMENT PART THAT IS EQUIVALENT IN PERFORMANCE AND DURABILITY MAY BE USED IN NON-WARRANTY MAINTENANCE OR REPAIRS, AND SHALL NOT REDUCE THE WARRANTY OBLIGATION OF THE COMPANY.

THE COMPANY IS LIABLE FOR DAMAGES TO OTHER ENGINE COMPONENTS CAUSED BY THE FAILURE OF A WARRANTED PARTS STILL UNDER WARRANTY.

THE WARRANTY DOES NOT APPLY TO THOSE UNITS WHICH HAVE BEEN DAMAGED BY NEGLIGENCE OF INSTRUCTION LISTED IN THE OWNER/OPERATOR MANUAL FOR PROPER USE AND MAINTENANCE OF THE UNITS, ACCIDENT MISHANDLING, ALTERATION, ABUSE, IMPROPER LUBRICATION, USE OF ANY PARTS OR ACCESSORIES OTHER THAN THOSE SPECIFIED BY THE COMPANY, OR OTHER CAUSES BEYOND THE COMPANY'S CONTROL.

THIS WARRANTY DOES NOT COVER THOSE PARTS REPLACED BY NORMAL WEAR OR HARMLESS CHANGES IN THEIR APPEARANCE.

THERE ARE NO OTHER EXPRESS WARRANTIES.

IMPLIED WARRANTIES INCLUDING THOSE OF MERCHANTABILITY AND FITNESS FOR A PARTICULAR PURPOSE **ARE LIMITED TO TWO (2) YEARS OF HOME USE [ONE (1) YEAR FOR ANY OTHER USE]** FROM THE ORIGINAL DELIVERY DATE.

LIABILITIES FOR INCIDENTAL OR CONSEQUENTIAL DAMAGE UNDER ANY AND ALL WARRANTIES ARE EXCLUDED.

SOME STATES DO NOT ALLOW LIMITATION ON HOW LONG AN IMPLIED WARRANTY LASTS OR EXCLUSION OR LIMITATION OF INCIDENTAL OR CONSEQUENTIAL DAMAGES, SO THE ABOVE LIMITATION OR EXCLUSION MAY NOT APPLY TO YOU.

THIS WARRANTY GIVES YOU SPECIFIC LEGAL RIGHTS, AND YOU MAY ALSO HAVE OTHER RIGHTS WHICH VARY FROM STATE TO STATE.

IF YOU NEED TO OBTAIN INFORMATION ABOUT THE NEAREST SERVICE CENTER, PLEASE CALL KOMATSU ZENOAH AMERICA INC. AT (770)-381-5147.

IMPORTANT: YOU WILL RECEIVE A WARRANTY REGISTRATION CARD AT TIME OF PURCHASE. PLEASE FILL OUT THE CARD AND SEND IT TO RedMax / KOMATSU ZENOAH AMERICA WITHIN SEVEN (7) DAYS. BE SURE TO KEEP A COPY FOR YOUR RECORDS.



RedMax®

KOMATSU ZENOAH AMERICA INC.
4344 Shackelford Road Suite 500
Norcross, Georgia 30093

RedMax Garantie limitée à 2 ans

Pièces en rapport avec les émissions de gaz d'échappement : KOMATSU ZENOAH AMERICA INC., par l'intermédiaire de n'importe quel revendeur RedMax, réparera gratuitement ou remplacera gratuitement pour l'acheteur initial et chaque acheteur successif toute(s) pièce(s) se révélant de constitution et/ou de montage défectueux pendant deux (2) ans à compter de la date initiale de livraison d'une unité. Les pièces en rapport avec les émissions de gaz d'échappement sont:

l'assemblage carburateur, l'assemblage bobine, le rotor, la bougie, le filtre à air, le filtre à carburant, la tubulure d'admission et les joints

Toutes autres pièces exceptées celles mentionnées ci-dessus : La société, par l'intermédiaire de n'importe quel revendeur RedMax, réparera gratuitement ou remplacera gratuitement pour l'acheteur initial toute(s) pièce (s) se révélant de constitution et/ou de montage défectueux pendant deux (2) ans en cas d'utilisation privée [un (1) an pour toute autre utilisation] à compter de la date de livraison initiale d'une unité. **Telles sont les limites de la garantie.**

Le coût du transport de l'unité jusqu'au revendeur RedMax et depuis celui-ci sera à la charge de l'acheteur.

L'acheteur ne supportera pas le coût de main d'oeuvre du diagnostic qui amène à la conclusion qu'une pièce garantie est défectueuse, si ce diagnostic est effectué chez le revendeur RedMax.

L'acheteur ou propriétaire a pour responsabilité d'effectuer l'entretien obligatoire tel que défini par le fabricant dans le manuel du propriétaire/de l'utilisateur.

Toute pièce garantie dont le remplacement n'est pas prévu dans le cadre de l'entretien obligatoire, ou pour laquelle est seulement prévue une inspection périodique pour "remplacement ou réparation si nécessaire" sera garantie pour la période de garantie. Toute pièce garantie arrivée à l'échéance de son premier remplacement prévu sera garantie jusqu'à celui-ci.

Toute pièce de rechange équivalente en performance ou en durabilité peut être utilisée pour l'entretien hors-garantie ou les réparations hors-garantie, et ce sans réduire l'obligation de garantie incombant à la société.

La société sera tenue responsable des dommages aux autres composants du moteur causés par la défaillance de pièce(s) garantie(s) en période de garantie.

La garantie ne s'applique pas aux unités endommagées par suite de: négligence dans la mise en oeuvre des instructions spécifiées dans le manuel du propriétaire/de l'utilisateur en vue d'une utilisation et d'un entretien correct, fausse manœuvre accidentelle, modification, utilisation abusive, lubrification incorrecte, utilisation de pièces ou d'accessoires autres que ceux spécifiés par la société, ou autres causes hors du contrôle de la société.

Cette garantie ne couvre pas les pièces remplacées en raison de leur usure normale ou de changements d'apparence sans effets.

Il n'existe aucune autre garantie explicite.

Les garanties implicites, celles de négociabilité du produit et de son adaptabilité à un usage défini incluses, **sont limitées** à deux (2) ans pour un usage privé [un (1) an pour toute autre utilisation] à compter de la date initiale de livraison.

Les responsabilités pour les dommages conséquents ou incidents sont exclues de toutes les garanties.

Certaines provinces n'autorisant pas les limitations à la durée des garanties implicites, ou les exclusions ou limitations relatives aux dommages incidents ou conséquents, la limitation indiquée ci-dessus peut ne pas vous être applicable.

Cette garantie vous donne des droits juridiques spécifiques, et vous pouvez également jouir d'autres droits variant d'une province à l'autre.

Si vous désirez obtenir des informations sur le centre de service le plus proche, veuillez appeler KOMATSU ZENOAH AMERICA INC. au (770)-381-5147

Note importante: vous recevrez une carte d'enregistrement de garantie au moment de l'achat. Veuillez la remplir et l'adresser à RedMax / KOMATSU ZENOAH AMERICA sous sept (7) jours en prenant soin de conserver une copie pour vous.



KOMATSU ZENOAH AMERICA INC.
4344 Shackelford Road Suite 500
Norcross, Georgia 30093



KOMATSU ZENOAH AMERICA INC.
4344 Shackleford Road Suite 500
Norcross, Georgia 30093